



KONICA MINOLTA

PRECISE COLOR COMMUNICATION

COLOR CONTROL FROM PERCEPTION TO INSTRUMENTATION



Giving Shape to Ideas



Knowing color. Knowing by color. In any environment, color attracts attention.

An infinite number of colors surround us in our everyday lives. We all take color pretty much for granted, but it has a wide range of roles in our daily lives: not only does it influence our tastes in food and other purchases, the color of a person's face can also tell us about that person's health.

Even though colors affect us so much and their importance continues to grow, our knowledge of color and its control is often insufficient, leading to a variety of problems in deciding product color or in business transactions involving color. Since judgement is often performed according to a person's impression or experience, it is impossible for everyone to visually control color accurately using common, uniform standards. Is there a way in which we can express a given color* accurately, describe that color to another person, and have that person correctly reproduce the color we perceive? How can color communication between all fields of industry and study be performed smoothly? Clearly, we need more information and knowledge about color.

**In this booklet, color will be used as referring to the color of an object.*

Contents

PART I

Why does an apple look red?	4
Human beings can perceive specific wavelengths as colors.	6
What color is this apple ?.....	8
Two red balls. How would you describe the differences between their colors to someone?	10
Hue. Lightness. Saturation. The world of color is a mixture of these three attributes.	12
Hue, lightness, saturation. Let's create a color solid.	14
By creating scales for hue, lightness, and saturation, we can measure color numerically.	16
Color meters make quantifying colors simple.	17
Let's look at some color spaces.	18
Color meters excel at reporting even minute color differences.	22
Even if colors look the same to the human eye, measurements with a color meter can point out slight differences.	24

PART II

Differences in the color recognition process between the human eye and color meters.....	28
What about the components of light (and color)? Let's take a look.	30
Let's measure various colors with a color meter.	32
Even though it's actually the same color, it looks different. Why?	34
Colors look different according to the light source.	36
A complex problem: Metamerism	38
Colors also look different according to the subject conditions and environment.	40
Spectrophotometers solve these problems easily and quickly.	43
Understanding important specifications	44
Measuring Special Colors	52
Notes for Measurement (Subjects and Environment).....	54

PART III

New Color Difference Formula (CIE DE2000)	55
---	----

PART IV

COLOR TERMS	59
-------------------	----

Let's study color.

Even when we just look around, a wide variety of colors is readily visible. We are surrounded by an infinite variety of colors in our daily lives. However, unlike length or weight, there is no physical scale for measuring color, making it unlikely that everyone will express it in the same way when asked what a certain color is. For example, if we say "blue ocean" or "blue sky", each individual will imagine different blue colors, because their color sensitivity and past experiences are different. This is the difficulty with color.

We also do not understand the mechanism of commonplace phenomena concerning colors such as "Why do apples look red?".

This section describes important and useful information about colors.

Why does an apple look red?



No light, no color. The three elements of light, vision, and object are necessary for us to perceive object color.

In total darkness, we cannot know color. If we close our eyes, we cannot see the color of an object. And if there is no object, color does not exist. Light, vision, and object: if all three are not present, we cannot perceive color. But how can we tell the difference between colors, between the red of an apple and the yellow of a lemon?

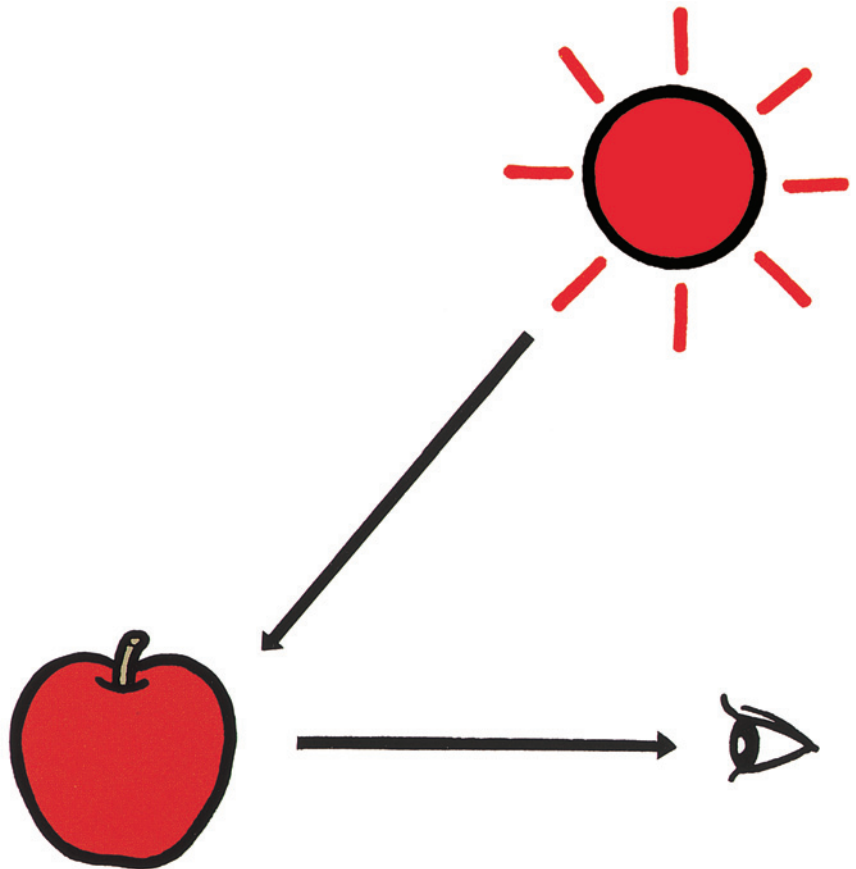

Human beings can perceive specific wavelengths as colors.

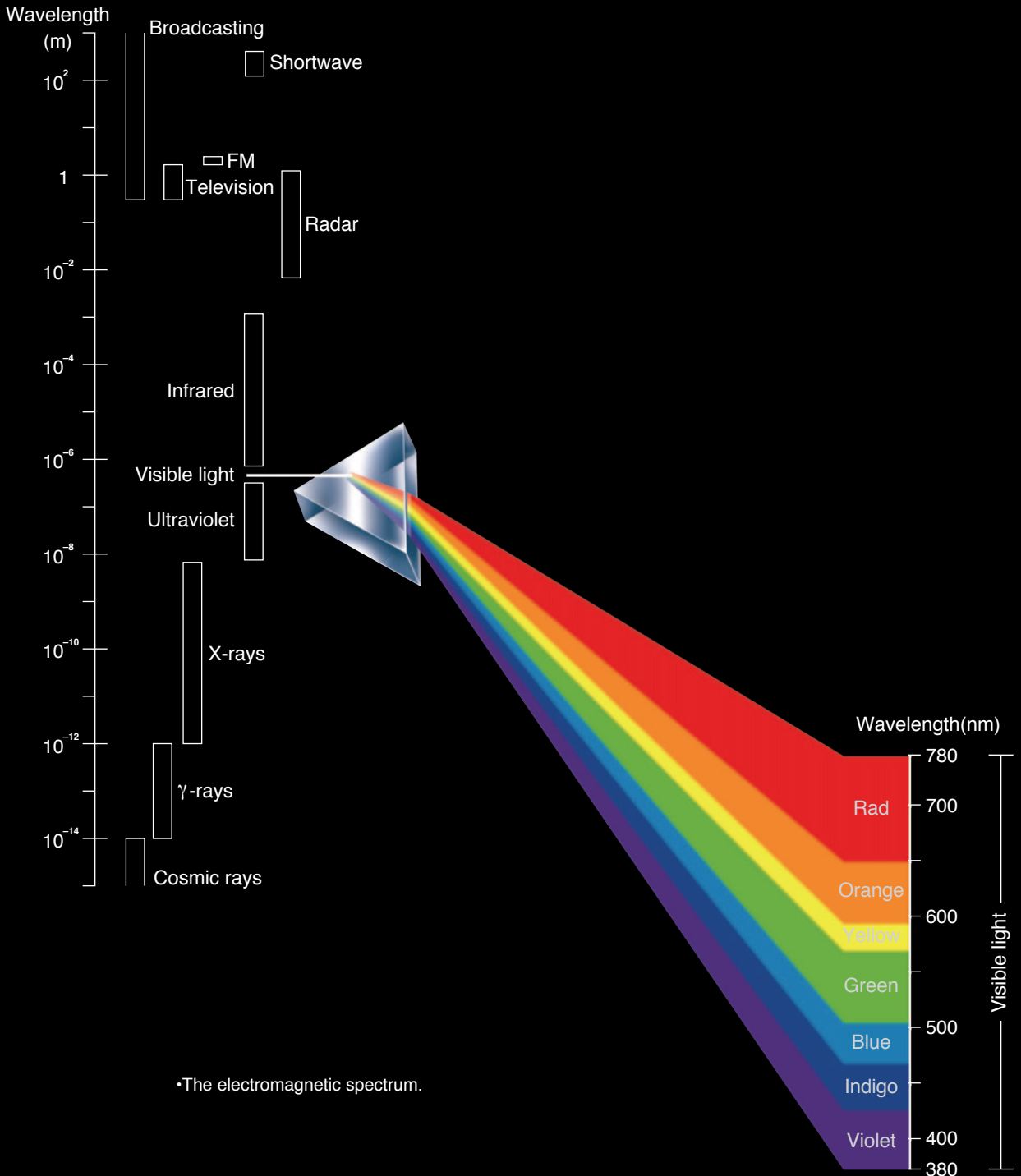

If we separate light into its different wavelengths, we create a spectrum. We can then create the different colors by mixing the separated wavelengths of light in varying intensities.

Most people know that if we pass light from the sun through a prism, we create a color distribution like a rainbow. This phenomenon was discovered by Isaac Newton, who also discovered universal gravity. This distribution of colors is called a spectrum; separating light into a spectrum is called spectral dispersion. The reason that the human eye can see the spectrum is because those specific wavelengths stimulate the retina in the human eye. The spectrum is arranged in the order red, orange, yellow, green, blue, indigo, and violet according to the different wavelengths*¹ of light; the light in the region with the longest wavelengths is seen as red, and the light in the region with the shortest wavelengths is seen as violet. The light region which the human eye can see is called the visible light region. If we move beyond the visible light region toward longer wavelengths, we enter the infrared region; if we move toward shorter wavelengths, we enter the ultraviolet region. Both of these regions cannot be seen by the human eye.

Light is just one portion of the various electromagnetic waves flying through space. The electromagnetic spectrum covers an extremely broad range, from electrical and radio waves with wavelengths of several thousand kilometers to gamma (γ) rays with wavelengths of 10^{-3} nm and shorter. The visible light region is only a very small portion of this: from approximately 380 nm to 780 nm*². The light reflected from an object and which we recognize as color is (with the exception of man-made monochromatic light) a mixture of light at various wavelengths within the visible region.

*¹ Wavelength: Light has wave characteristics; wavelength is the peak-to-peak distance of two adjacent waves.

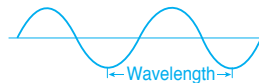

*² nm(nanometer): A unit of measure often used when discussing wavelengths of light; m(micrometer) is also sometimes used.

$$1 \text{ nm} = 10^{-9} \text{ m} = 10^{-6} \text{ mm} = 10^{-3} \text{ m}$$
$$1 \text{ m} = 10^6 \text{ nm} = 10^3 \text{ mm} = 10^3 \text{ m}$$



- A rainbow is created by sunlight passing through fine water droplets in the air, which act as prisms.

What color is this apple ?



Red!

Hmmm.
Burning red.

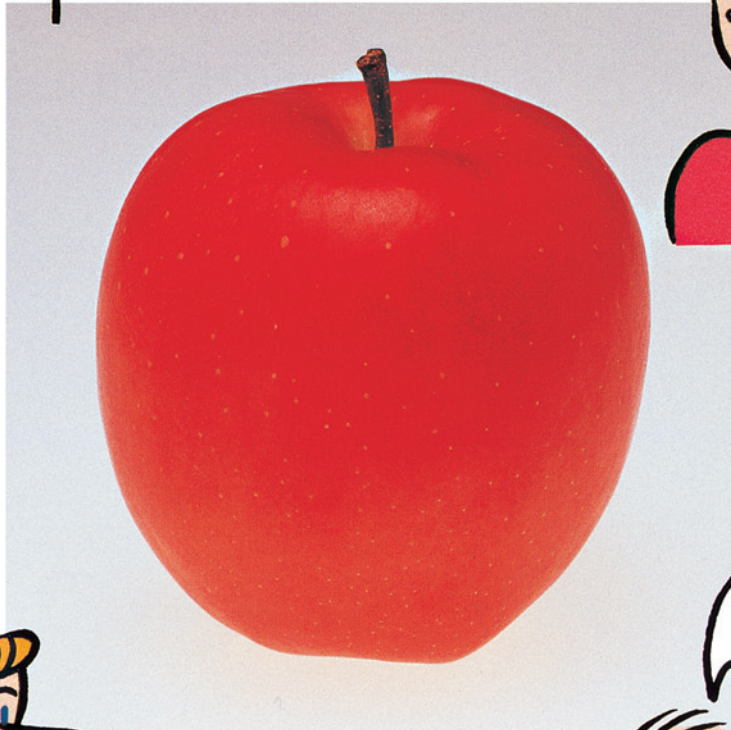

I'd say
crimson.

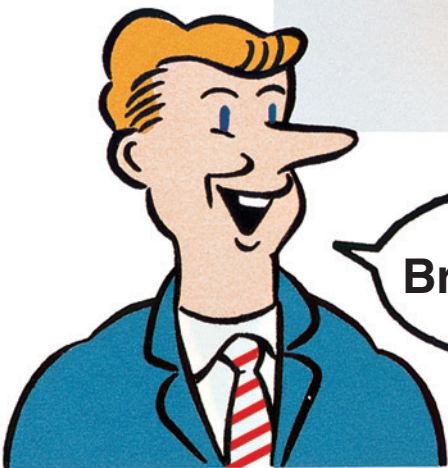

Bright Red.



A color expression often means ten different colors to ten different people.

“Name this color” is a very difficult thing to do.

If you show the same apple to four different people, you are bound to get four different answers.

Color is a matter of perception and subjective interpretation. Even if they are looking at the same object (in this case, an apple), people will draw upon different references and experiences and express the exact same color in vastly different words. Because there is such a wide variety of ways to express a color, describing a particular color to someone is extremely difficult and vague. If we describe the color of the apple to someone as “burning red”, can we expect them to be able to reproduce that color exactly? Verbal expression of color is too complicated and difficult. However, if there was a standard method by which colors could be accurately expressed and understood by anyone, color communication would be much smoother, simpler, and exact. Such precise color communication would eliminate color-related problems.

To what extent can words express color?

Common color names and systematic color names.

Words for expressing colors have always changed with the times. If we consider, for instance, the red we’ve been talking about, there are “vermillion”, “cinnabar”, “crimson”, “rose”, “strawberry”, and “scarlet”, to mention just a few. These are called common color names. By analyzing the color condition and adding adjectives such as “bright”, “dull”, and “deep”, we can describe the color a little more precisely. Terms such as the “bright red” used by the man on the facing page are called systematic color names. Although there are a variety of such ways to describe color, different people hearing just “crimson” or “bright red” will still interpret such expressions in different ways. So verbal expression of colors is still not accurate enough. Then how should colors be expressed to avoid the possibility of misunderstanding?



Two red balls.

How would you describe the differences between their colors to someone?

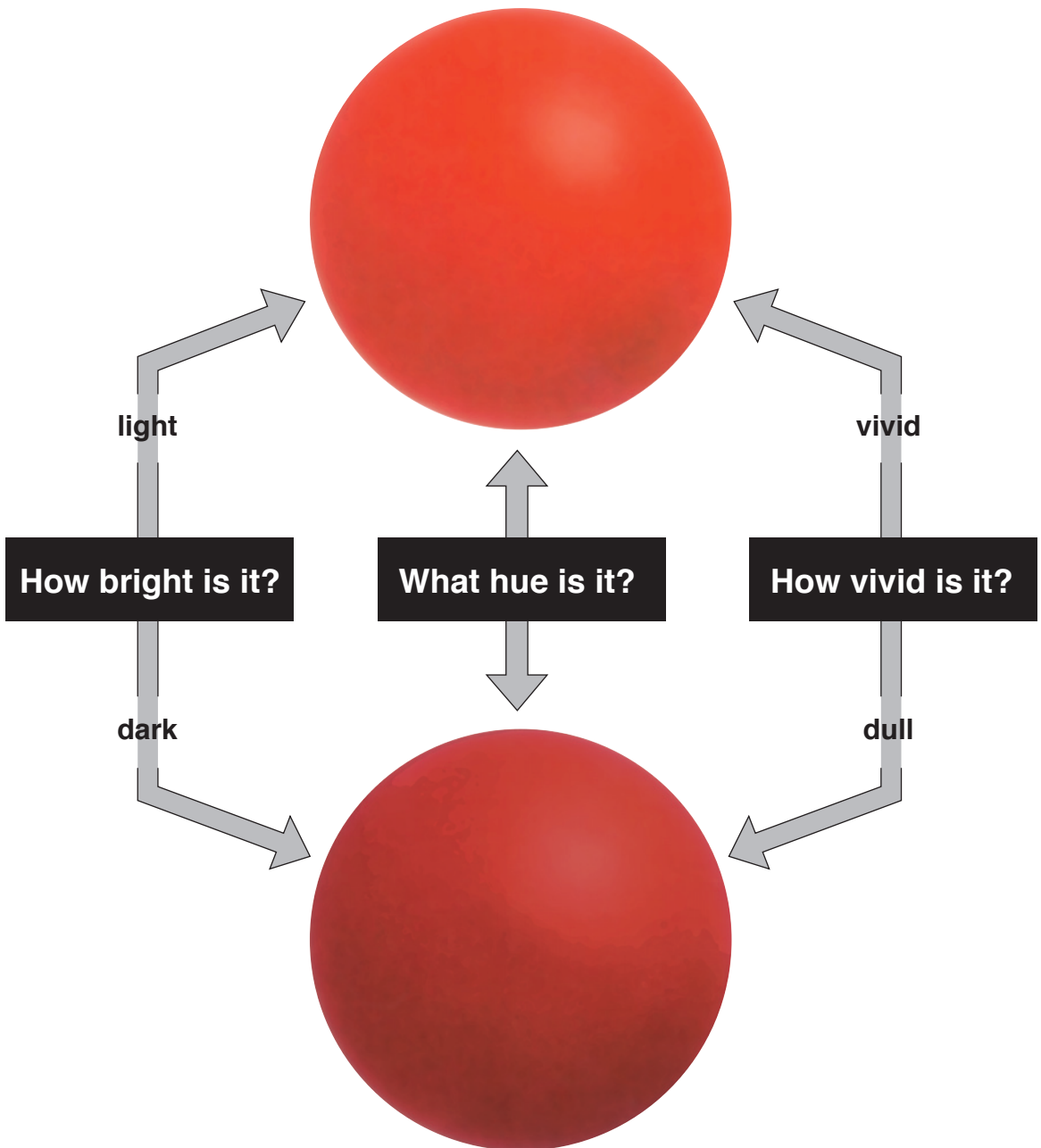

To better understand accurate color expression, let's take a look at the world of color.

There are many different “red” colors. The reds of the two balls at left are very similar. How are they different?

Two red balls are shown at left. At first glance they look the same, but upon closer examination you realize they are different in several ways. The color of both is red, but the color of the upper ball is somewhat brighter and the color of the lower ball is thus darker. Also, the color of the upper ball appears vivid. So you can see that even though they both appear red, the colors of the two balls are different. When colors are classified, they can be expressed in terms of their hue (color), lightness (brightness), and saturation (vividness).

Hue. Lightness. Saturation. The world of color is a mixture of these three attributes.

Figure 1: Color wheel

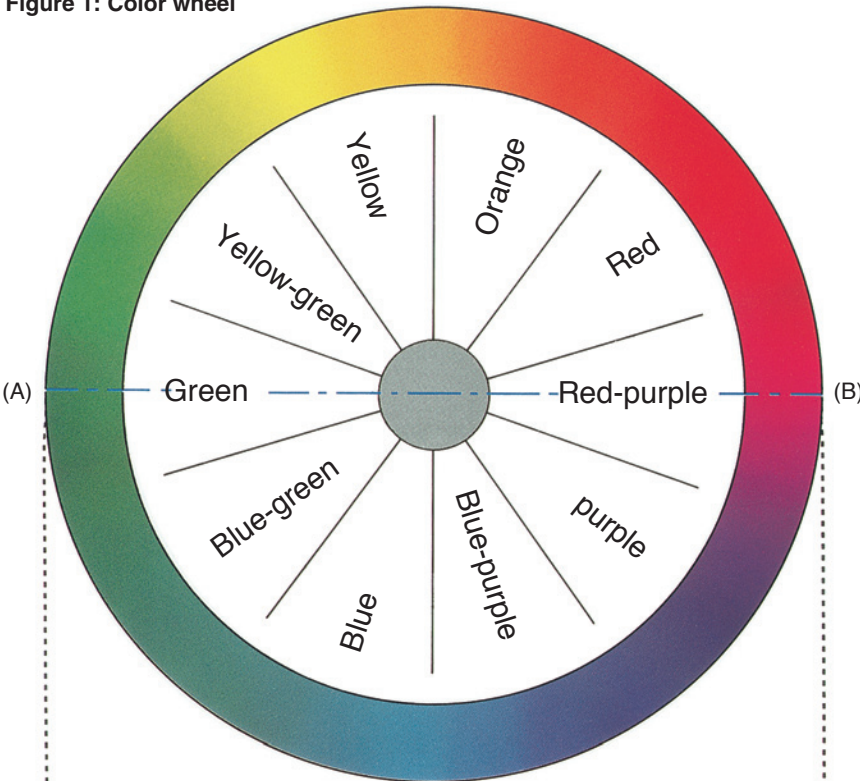

Figure 2: Changes in lightness and saturation for red-purple and green

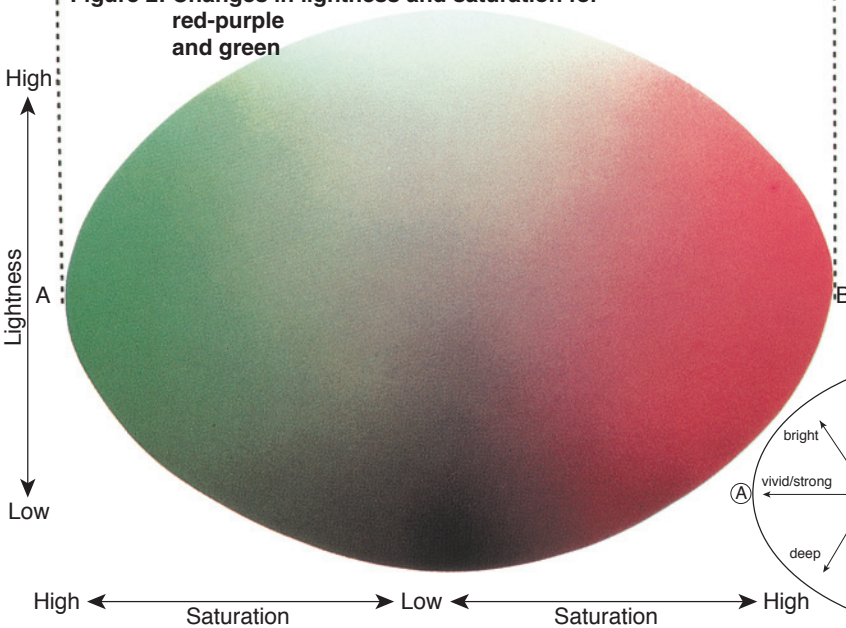
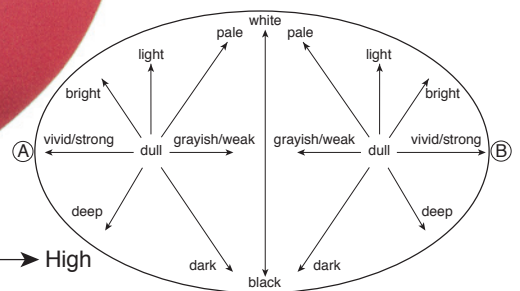

Figure 3: Adjectives related to colors



Hue, lightness, and saturation: This is the world of color.

Hue Red, yellow, green, blue... Hues form the color wheel.

Apples are red, lemons are yellow, the sky is blue; that's how we all think of color in everyday language. Hue is the term used in the world of color for the classifications of red, yellow, blue, etc. Also, although yellow and red are two completely different hues, mixing yellow and red together results in orange (which is sometimes referred to as yellow-red), mixing yellow and green results in yellow-green, mixing blue and green results in blue-green, and so on. The continuum of these hues results in the color wheel shown in Figure 1.

Lightness Bright colors, dark colors. The lightness of colors changes vertically.

Colors can be separated into bright and dark colors when their lightnesses (how bright they are) are compared. Take, for example, the yellows of a lemon and a grapefruit. Without a doubt, the yellow of the lemon is much brighter. How about the yellow of a lemon and the red of a sweet cherry. Again, the yellow of the lemon is brighter, right? This lightness can be measured independently of hue. Now take a look at Figure 2. This figure is a cross section of Figure 1, cut along a straight line between A (Green) and B (Redpurple). As the figure shows, lightness increases toward the top and decreases toward the bottom.

Saturation Vivid colors, dull colors. Saturation changes outward from the center.

Going back to yellow, how do you compare the yellows of a lemon and a pear? You might say the yellow of the lemon is brighter, but more to the point in this case, it is vivid, while the yellow of the pear is dull. This is another big difference, but this time one of color saturation or vividness. This attribute is completely separate from those of both hue and lightness. If we look at Figure 2 again, we can see that saturation changes for red-purple and green respectively as the horizontal distance from the center changes. Colors are dull near the center and become more vivid as we move away from the center. Figure 3 shows general adjectives used to describe the lightness and saturation of colors. To see what the words express, look back at Figure 2 again.

Hue, lightness, saturation.

Let's create a color solid.

If we use the change of lightness as the axis of the color wheel and the change of saturation as the spokes...

Hue, lightness, and saturation. These three elements are the three color attributes, and can be put together to create the three dimensional solid shown in Figure 4. Hues form the outer rim of the solid, with lightness as the center axis and saturation as the horizontal spokes. If the actual colors which exist in the world were distributed around the solid shown in Figure 4, the color solid shown in Figure 5 would be created. The shape of the color solid is somewhat complicated because the size of the steps for saturation are different for each hue and lightness, but the color solid helps us to better visualize the relationship between hue, lightness, and saturation.

Figure 4:
Three-dimensional
(hue, lightness, saturation) solid

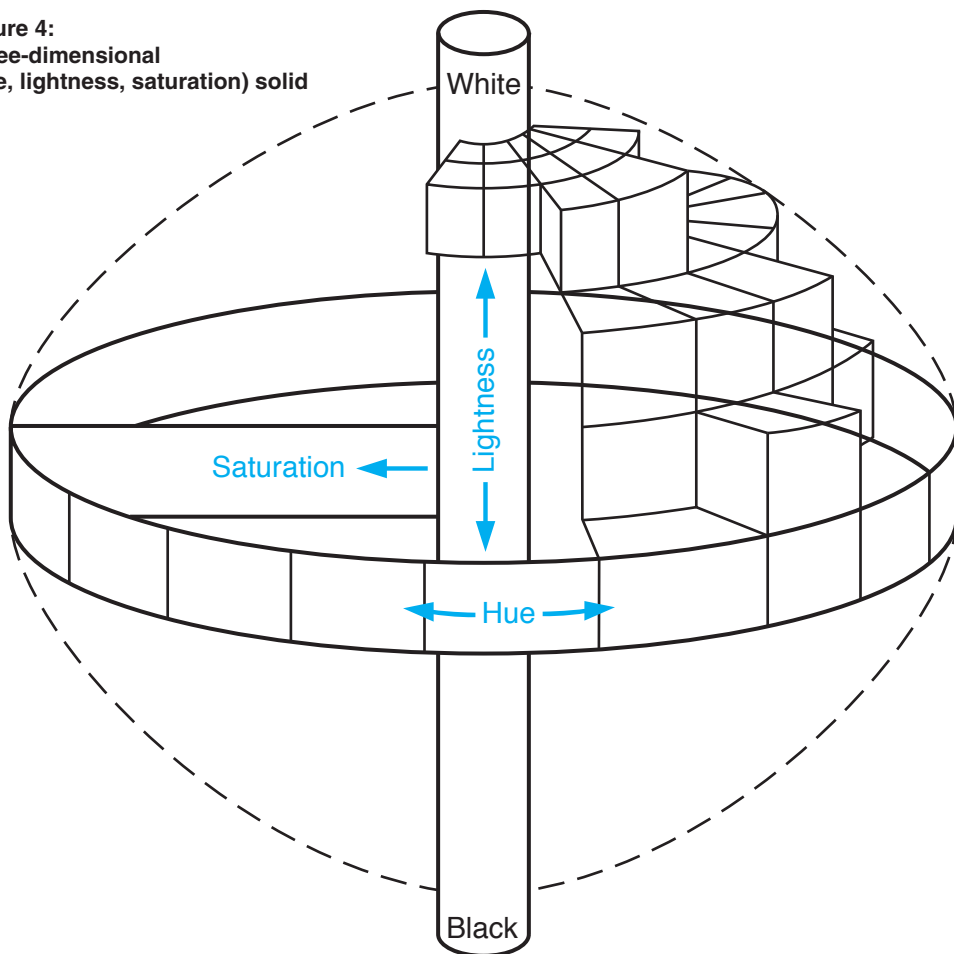
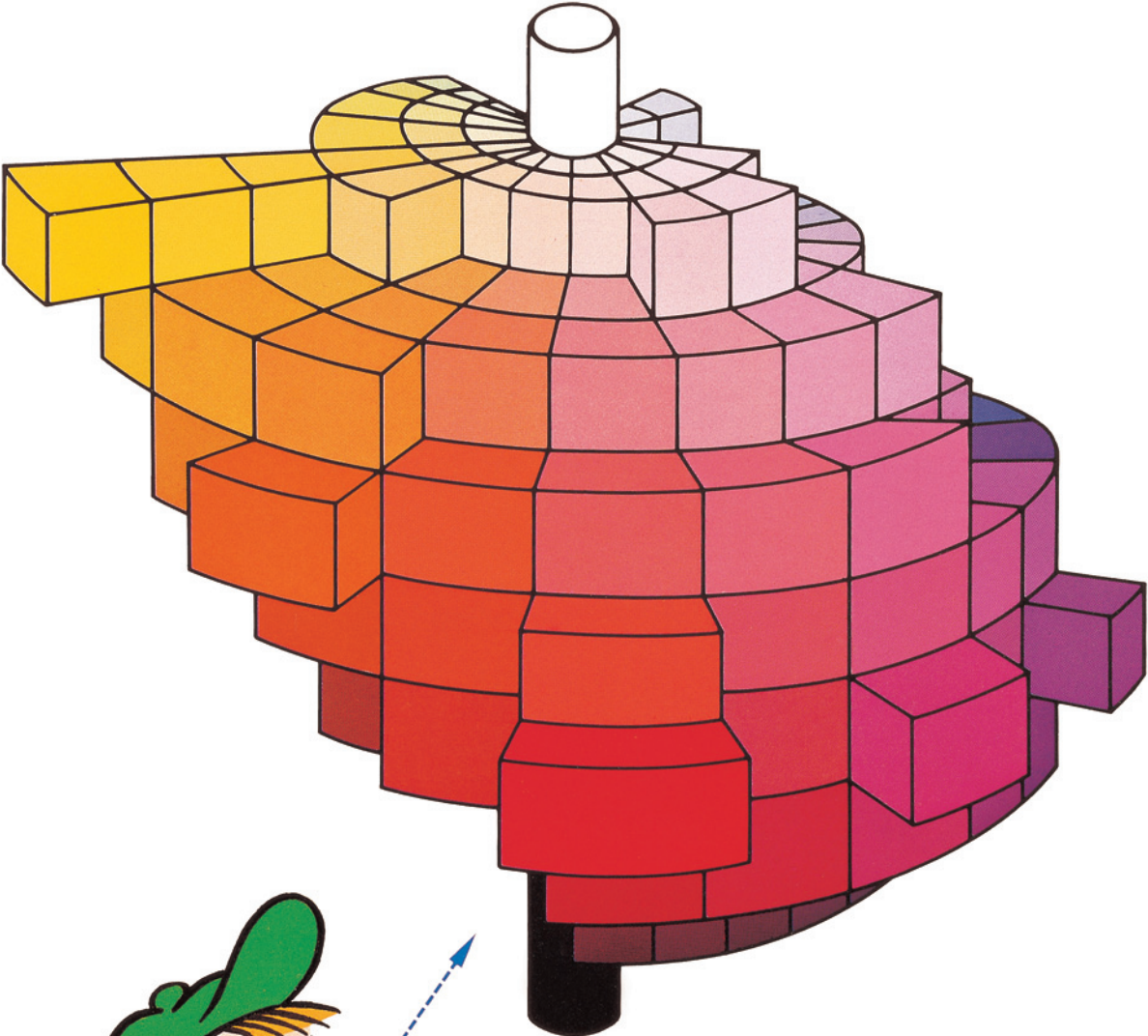

Figure 5: Color solid



If we look for the color of the apple on the color solid, we can see that its hue, lightness, and saturation intersect in the red area.

By creating scales for hue, lightness, and saturation, we can measure color numerically.

History of expressing colors numerically

Everyone would find it useful to be able to communicate about color more easily and accurately. In the history of color, many people have tried to devise their own methods for expressing color quantitatively. These methods provided a way of expressing colors numerically, in much the same way that we express length or weight. For example, in 1905 the American artist A. H. Munsell devised a method for expressing colors by using a great number of paper color chips of different hue (Munsell Hue), lightness (Munsell Value), and saturation (Munsell Chroma) for visual comparison with a specimen color. This method was the basis of the Munsell Renotation System, which is the Munsell Color System presently in use. In this system, any given color is expressed as a letter/number combination ($H\ V/C$) in terms of its hue (H), value (V), and chroma (C) as visually evaluated using the Munsell Color Charts.

Other methods for expressing color numerically were developed by an international organization concerned with light and color, the Commission Internationale de l'Eclairage (CIE). The two most widely known of these methods are the Yxy color space, devised in 1931 based on the tristimulus values XYZ defined by CIE, and the $L^*a^*b^*$ color space, devised in 1976 to provide more uniform color differences in relation to visual differences. After various improvements, color spaces* such as these are now used throughout the world for color communication.

*Color space: Method for expressing the color of an object or a light source using some kind of notation such as numbers, which is composed of three elements.



Color meters make quantifying colors simple.

By using a color meter, we can obtain results instantly for each color space.

If we measure the color of the apple, we get the following results:



$L^*a^*b^*$ color space



$L^* = 43.31$
 $a^* = 47.63$
 $b^* = 14.12$

$L^*C^*h^*$ color space



$L^* = 43.31$
 $C^* = 49.68$
 $h = 16.5$

XYZ (Yxy) color space



$Y = 13.37$
 $x = 0.4832$
 $y = 0.3045$

Let's look at some color spaces.

$L^*a^*b^*$ color space

The $L^*a^*b^*$ color space (also referred to as CIELAB) is presently one of the most popular color spaces for measuring object color and is widely used in virtually all fields. It is one of the uniform color spaces defined by CIE in 1976 in order to reduce one of the major problems of the original Yxy color space: that equal distances on the x, y chromaticity diagram did not correspond to equal perceived color differences.

In this color space, L^* indicates lightness and a^* and b^* are the chromaticity coordinates. Figure 6 shows the a^*, b^* chromaticity diagram. In this diagram, the a^* and b^* indicate color directions: $+a^*$ is the red direction, $-a^*$ is the green direction, $+b^*$ is the yellow direction, and $-b^*$ is the blue direction. The center is achromatic; as the a^* and b^* values increase and the point moves out from the center, the saturation of the color increases. Figure 8 is a representation of the color solid for the $L^*a^*b^*$ color space; Figure 6 is a view of this solid cut horizontally at a constant L^* value.

If we measure the apple using the $L^*a^*b^*$ color space, we obtain the following values.



$L^* = 43.31$
 $a^* = 47.63$
 $b^* = 14.12$

To see what color these values represent, let's first plot the a^* and b^* values ($a^* = +47.63$, $b^* = +14.12$) on the $L^*a^*b^*$ diagram in Figure 6 to obtain point A, which shows the chromaticity of the apple. Now, if we cut the solid of Figure 6 vertically through point A and the center, we obtain a view of lightness versus saturation, part of which is shown in Figure 7. On this diagram, point B, which is the lightness of the apple, can be determined ($L^* = 43.31$). The color of this apple can be expressed like this: A vivid color with red hue.

Figure 6:
 $L^*a^*b^*$ color space chromaticity diagram (Hue and Saturation)

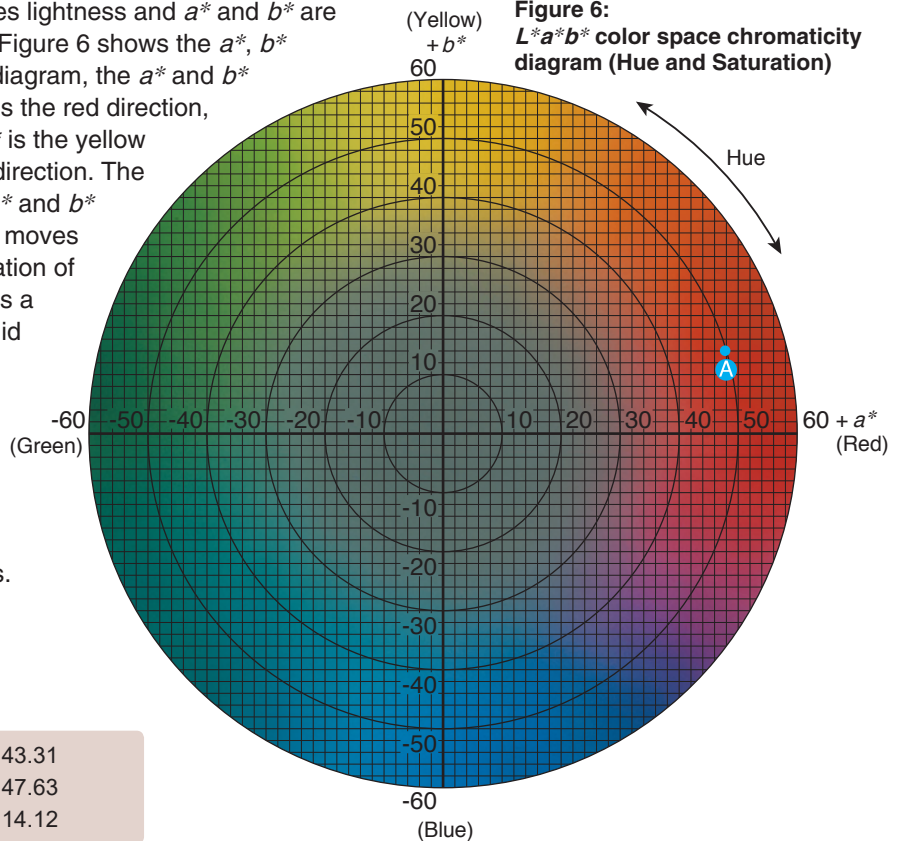

Figure 7:
 Part of $L^*a^*b^*$ chromaticity diagram (Lightness vs. Saturation)

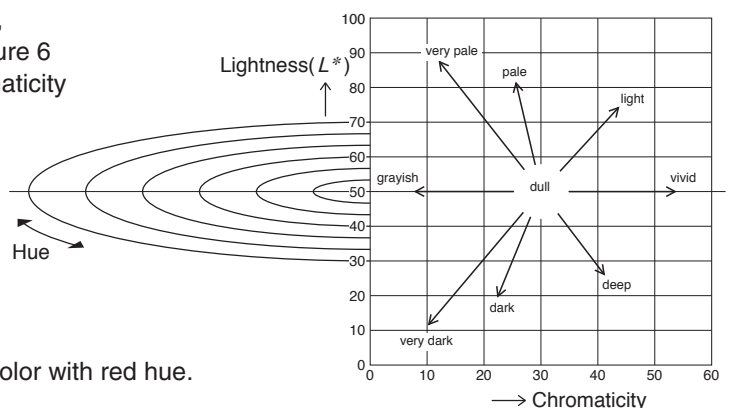
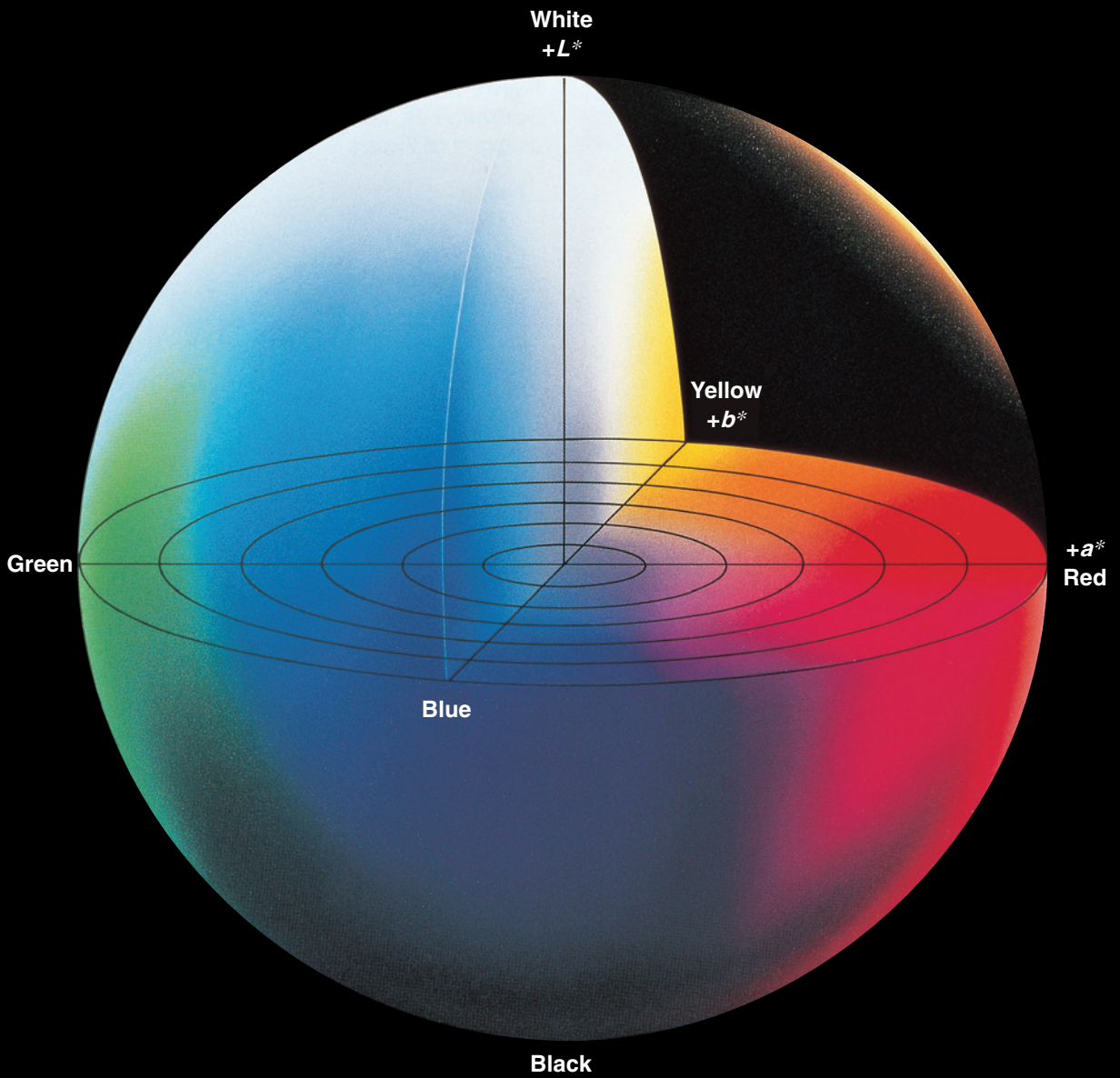

Figure 8: Representation of color solid for $L^*a^*b^*$ color space



L*C*h color space

The L^*C^*h color space uses the same diagram as the $L^*a^*b^*$ color space, but uses cylindrical coordinates instead of rectangular coordinates. In this color space, L^* indicates lightness and is the same as the L^* of the $L^*a^*b^*$ color space, C^* is chroma, and h is the hue angle. The value of chroma C^* is 0 at the center and increases according to the distance from the center. Hue angle h is defined as starting at the $+a^*$ axis and is expressed in degrees; 0° would be $+a^*$ (red), 90° would be $+b^*$ (yellow), 180° would be $-a^*$ (green), and 270° would be $-b^*$ (blue). If we measure the apple using the L^*C^*h color space, we get the results shown below. If we plot these values on Figure 9, we obtain point A.



$L^* = 43.31$
 $C^* = 49.68$
 $h = 16.5$

Chroma $C^* = \sqrt{(a^*)^2 + (b^*)^2}$

Hue angle $h_{ab} = \tan^{-1}\left(\frac{b^*}{a^*}\right)$

Figure 9:
Portion of a^*, b^* chromaticity diagram of Figure 6

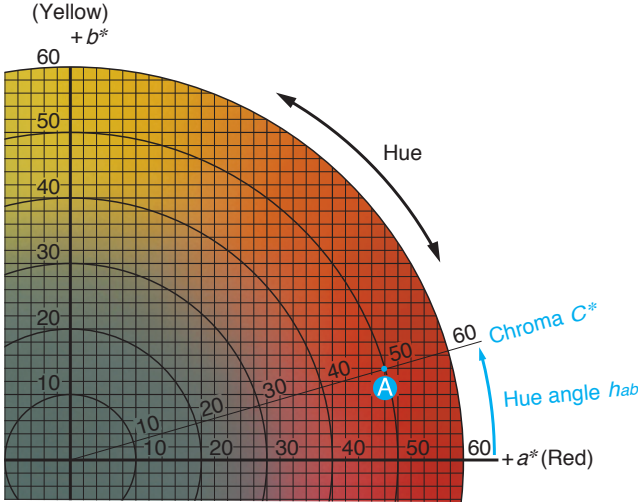

Chroma and lightness

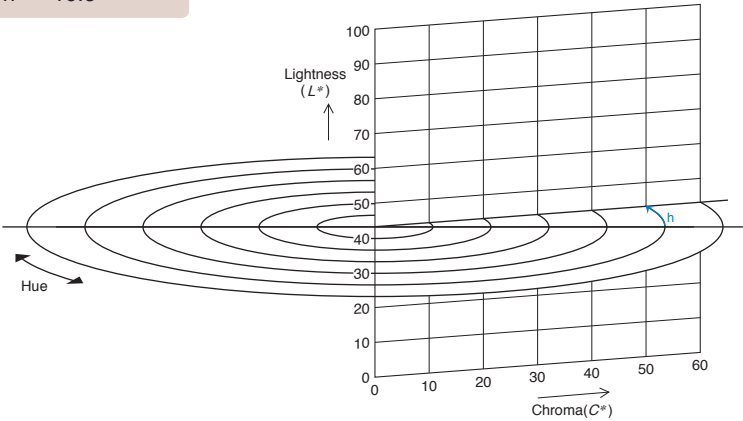

XYZ Color Space

XYZ tristimulus values and the associated Yxy color space form the foundation of present CIE color spaces. The concept for the XYZ tristimulus values is based on the three-component theory of color vision, which states that the eye possesses receptors for three primary colors (red, green, and blue) and that all colors are seen as mixtures of these three primary colors. The CIE in 1931 defined the Standard Observer to have the color-matching functions, $\bar{x}(\lambda)$, $\bar{y}(\lambda)$, and $\bar{z}(\lambda)$ shown in Figure 10b below. The XYZ tristimulus values are calculated using these Standard Observer color-matching functions.

The tristimulus values XYZ are useful for defining a color, but the results are not easily visualized. Because of this, the CIE also defined a color space in 1931 for graphing color in two dimensions independent of lightness; this is the Yxy color space, in which Y is the lightness (and is identical to tristimulus value Y) and x and y are the chromaticity coordinates calculated from the tristimulus values XYZ (for details, refer to p. 56). The CIE x, y chromaticity diagram for this color space is shown in Figure 10a.

In this diagram, achromatic colors are toward the center of the diagram, and the chromaticity increases toward the edges. If we measure the apple using the Yxy color space, we obtain the values $x=0.4832$, $y=0.3045$ as the chromaticity coordinates, which correspond to point A on the diagram in Figure 10a; the Y value of 13.37 indicates that the apple has a reflectance of 13.37% (compared to an ideal reflecting diffuser with a reflectance of 100%).



Y = 13.37
 x = 0.4832
 y = 0.3045

Figure 10a: xy chromaticity diagram

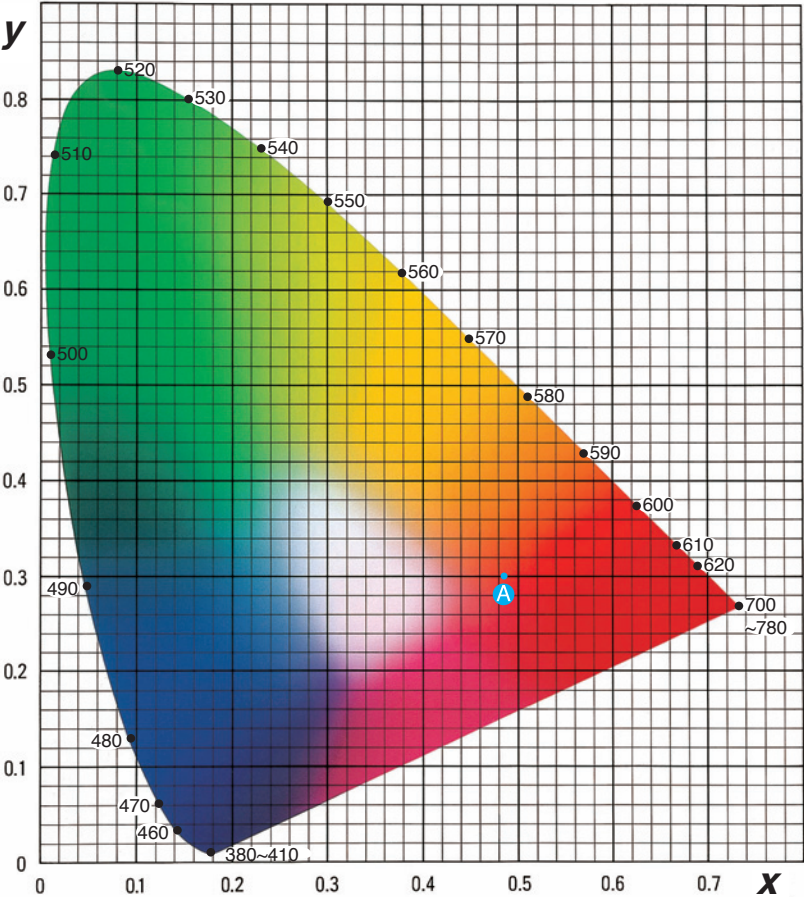
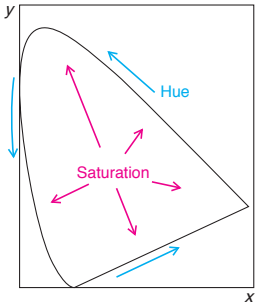
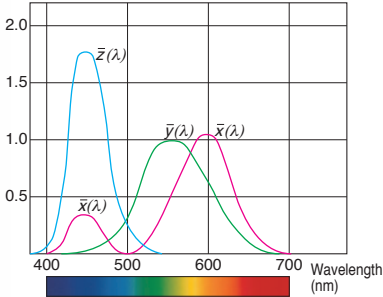
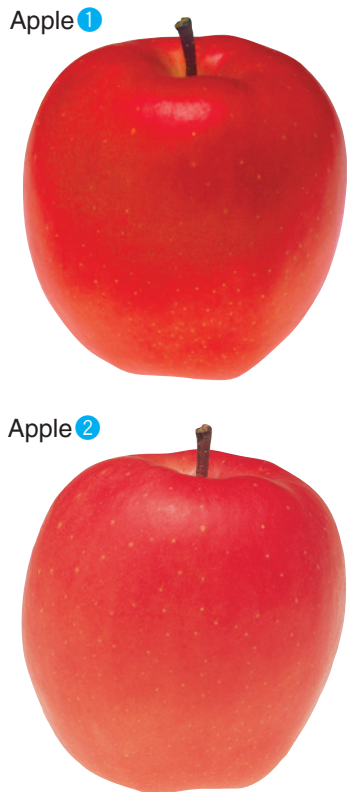

Figure 10b: Spectral response corresponding to the human eye (Color-matching functions of the 1931 Standard Observer)



Color meters excel at reporting even minute color differences.



Numerical values show the difference.

Minute color differences are the biggest headache anywhere that color is used. But with a color meter, even minute color differences can be expressed numerically and easily understood. Let's use the $L^*a^*b^*$ and $L^*C^*h^*$ color spaces to look at the color difference between two apples. Using apple 1's color ($L^*=43.31$, $a^*=+47.63$, $b^*=+14.12$) as the standard, if we measure the difference of apple 2's color ($L^*=47.34$, $a^*=+44.58$, $b^*=+15.16$) from apple 1's color, we get the results shown in display A below. The difference is also shown on the graph in Figure 12. The diagram of Figure 11 should make color difference in the $L^*a^*b^*$ color spaces easier to understand.

A: $L^*a^*b^*$ color difference B: $L^*C^*h^*$ color difference

$\Delta L^* = +4.03$
 $\Delta a^* = -3.05$
 $\Delta b^* = +1.04$
 $\Delta E^* = 5.16$

$\Delta L^* = +4.03$
 $\Delta C^* = -2.59$
 $\Delta H^* = +1.92$
 $\Delta E^* = 5.16$

Figure 11:
Color difference
in the $L^*a^*b^*$ color space

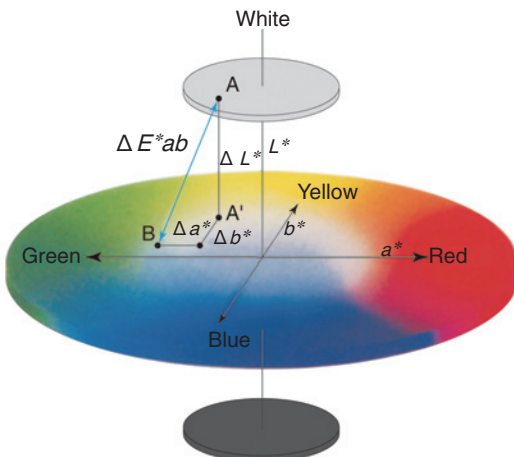

A: Target color
 B: Specimen color
 A': Target color at the same lightness as specimen color

In the $L^*a^*b^*$ color space, color difference can be expressed as a single numerical value, E^*_{ab} , which indicates the size of the color difference but not in what way the colors are different. E^*_{ab} is defined by the following equation

$$E^*_{ab} = \sqrt{(L^*)^2 + (a^*)^2 + (b^*)^2}$$

If we put the values $L^*=+4.03$, $a^*=-3.05$, and $b^*=+1.04$ from display A above into this equation, we get $E^*_{ab}=5.16$. If we measure the color difference between the two apples using the $L^*C^*h^*$ color space, we get the results shown in display B above. The value of L^* is the same as the value measured in the $L^*a^*b^*$ color space. $C^*=-2.59$, indicating that apple 2's color is less saturated. The hue difference between the two apples, H^* (defined by the equation $H^*_{ab} = \sqrt{(E^*)^2 - (L^*)^2 - (C^*)^2}$) is +1.92, which if we look at Figure 12, means that the color of apple 2 is closer to the $+b^*$ axis, and so is more yellow.

• “(delta) indicates difference

Figure 12: Portion of a^* , b^* chromaticity diagram



Although words are not as exact as numbers, we can use words to describe color differences. Figure 13, shows some of the terms used to describe differences in lightness and chroma; the terms shown in this figure indicate the direction of color difference, but unless an additional modifier (slightly, very, etc.) is used, they do not indicate the degree of color difference. If we look at the plotted values for the two apples, we see that we should say that the color of apple 2 is "paler" than that of apple 1; since the chroma difference is not very great, we might also add a modifier, saying that apple 2 is "slightly paler" to indicate the degree of difference.

Figure 13: Terms for describing differences in chroma and lightness

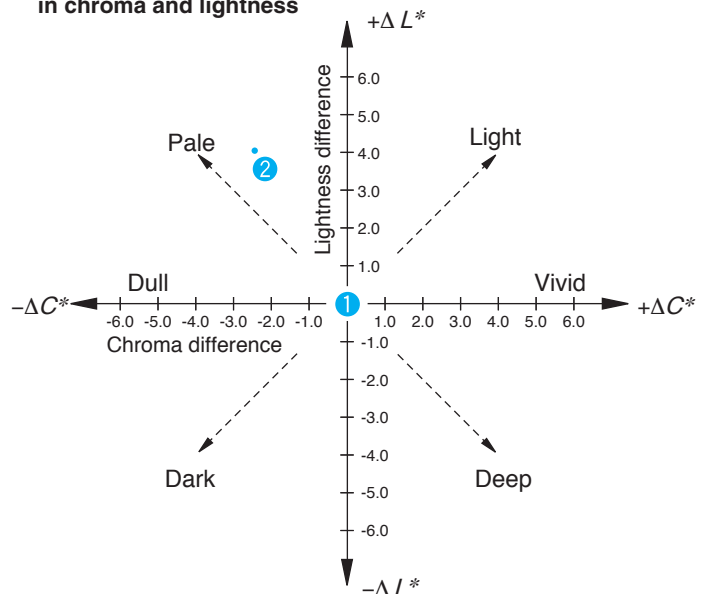

Even if colors look the same to the human eye, measurements with a color meter can point out slight differences.

Even if two colors look the same to the human eye, as in the example of the two apples on p. 22, slight differences may be found when the colors are measured with a color meter. In addition, the color meter expresses such differences exactly in numerical form. If for some reason the color of a product was wrong and the product was shipped without the problem being noticed, and the customer complained as a result....The effect would not be limited to only the sales department or the production department, it would hurt the reputation of the entire company. Color control plays a very important role in preventing such problems from occurring.

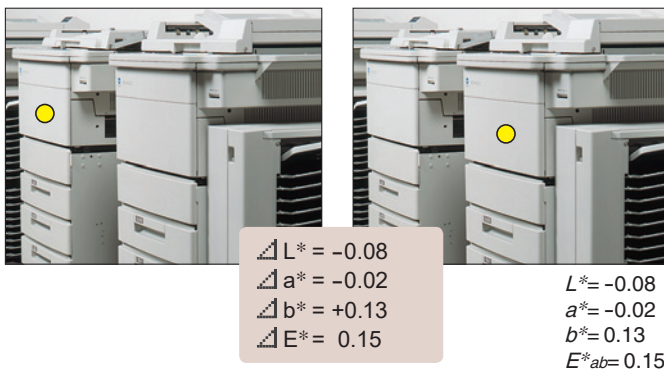
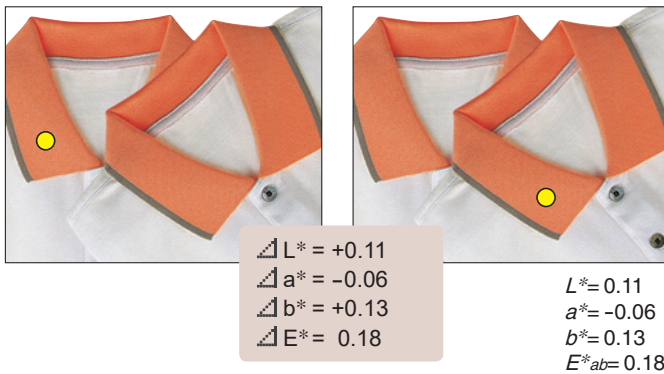
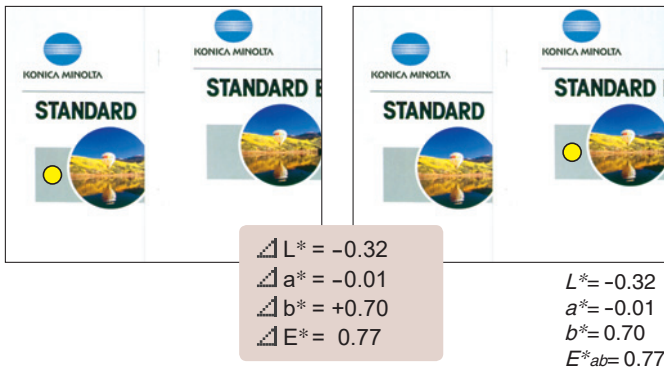

● indicates the measurement point.

An example of quality control using a color meter.

Let's look at how useful a color meter can be for color control.

Company K manufactures exterior plastic parts ordered by company B. Company B also orders similar parts from companies other than Company K. At Company K, a full-time staff of inspectors is in charge of controlling color on the production line and visually evaluates products in comparison to color samples. Visual inspection depends on the eyes of skilled inspectors to determine whether or not a product is within the acceptance range as defined by the color samples. This work cannot be performed by anyone; it requires years of experience to develop an ability for visual inspection. As a result, the number of people who can do this work is limited. Also, the process can be performed only for a limited period of time per day or week, and the evaluation will vary according to the inspector's age and physical condition. Sometimes, company K complained that the color of parts delivered by Company K did not match those of other suppliers and so company B returned the parts to Company K. Company K decided to utilize color meters for color control of its products on the production line. The color meters became very popular, because they were handheld and could be used even on the production line, they were easy enough for anyone to use, and measurements were quick so they could be used at any time. Further, the data measured by the color meter were submitted with the products at the time of delivery as proof of the company's quality control.



Basic Knowledge for Spectrophotometer Selection

So far we understand that using color meters enables expressing colors numerically to ensure smooth and easy color communication as well as to analyze colors from various angles. Let's study more about the special colors and conditions that influence the selection of color meters.

Differences in the color recognition process between the human eye and color meters

We can see the light from wavelengths in the visible light region; however, light is not a color in itself. As the definition specifies "the radiant energy which can stimulate the retina in the eye to produce a sense of sight", the concept of "color" is formed when light enters the eye and stimulates the retina, and the brain reacts to it.

Among the colors of the spectrum (red, orange, yellow, green, etc.), three colors of red, green, and blue are generally described as the three primary colors of light. It is believed that we can perceive colors because the eye has three types of cones (color sensors) which are sensitive to these three primary colors. Figure 14 shows the spectral response curves corresponding to the human eye, according to the CIE definition of the 1931 Standard Observer. These are referred to as the color-matching functions. $\bar{x}(\lambda)$ has a high response in the red wavelength region, $\bar{y}(\lambda)$ has a high response in the green wavelength region, and $\bar{z}(\lambda)$ has a high response in the blue wavelength region. The colors that we see are the result of different $\bar{x}(\lambda)$, $\bar{y}(\lambda)$, and $\bar{z}(\lambda)$ proportions (stimuli) in the light received from an object.

Tristimulus method and spectrophotometric method

As shown in Figure 15b, the tristimulus method measures the light reflected from the object using three sensors filtered to have the same response to $\bar{x}(\lambda)$, $\bar{y}(\lambda)$, and $\bar{z}(\lambda)$ as the human eye and thus directly measures the tristimulus values X , Y , and Z . On the other hand, the spectrophotometric method shown in Figure 15c utilizes a diffraction grating to separate the light reflected from the object into a spectrum, and then uses multiple sensors (36 in the CM-700d) to measure the spectral reflectance at each wavelength or in each narrow wavelength range. The instrument's microcomputer then calculates the tristimulus values from the spectral reflectance data by performing integration. For the apple used in the example, the tristimulus values are $X=21.21$, $Y=13.37$, and $Z=9.32$; These tristimulus values can then be used to calculate values in other color spaces such as Yxy or $L^*a^*b^*$. Figure 16 shows how the tristimulus values X , Y , and Z are determined. Light with spectral distribution **A** reflected by the specimen (apple) is

Figure 14: Spectral response corresponding to the human eye

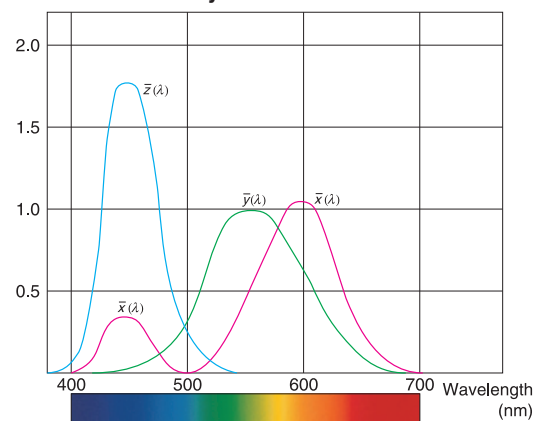
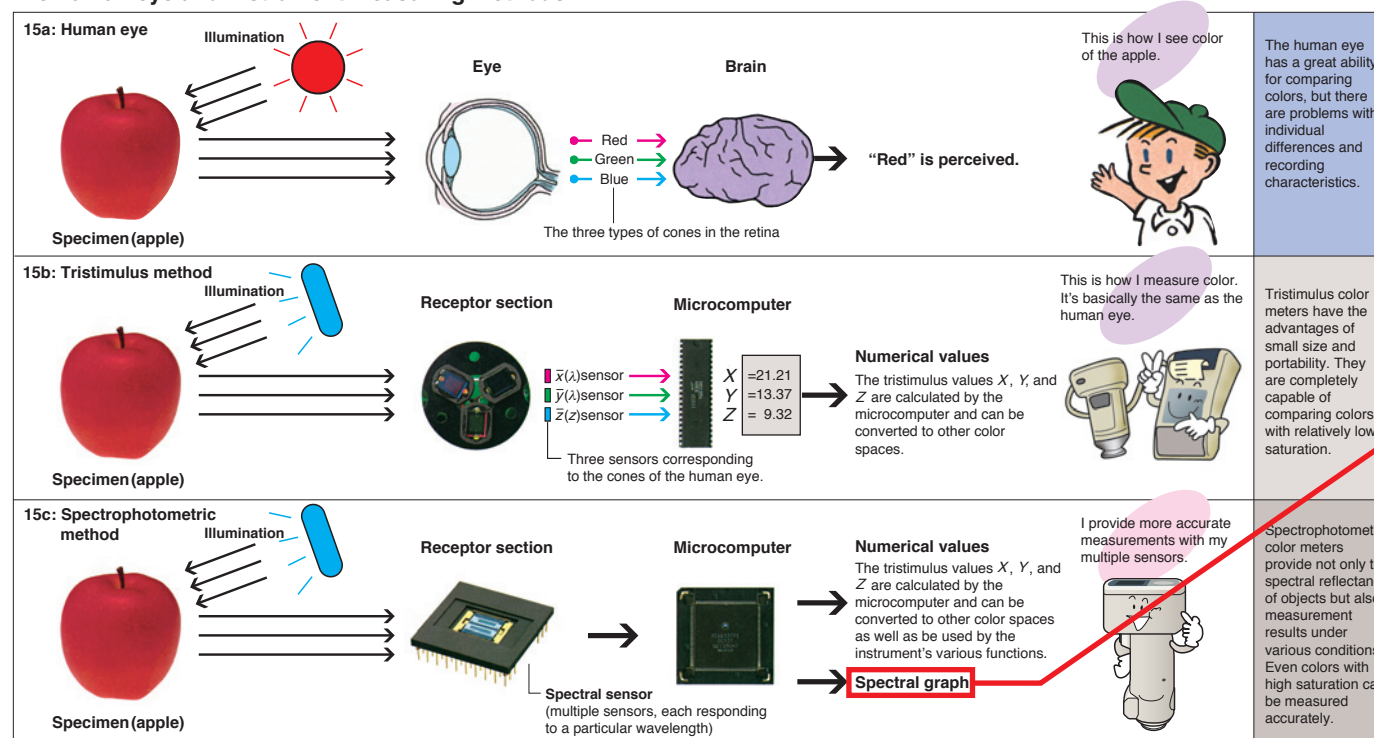
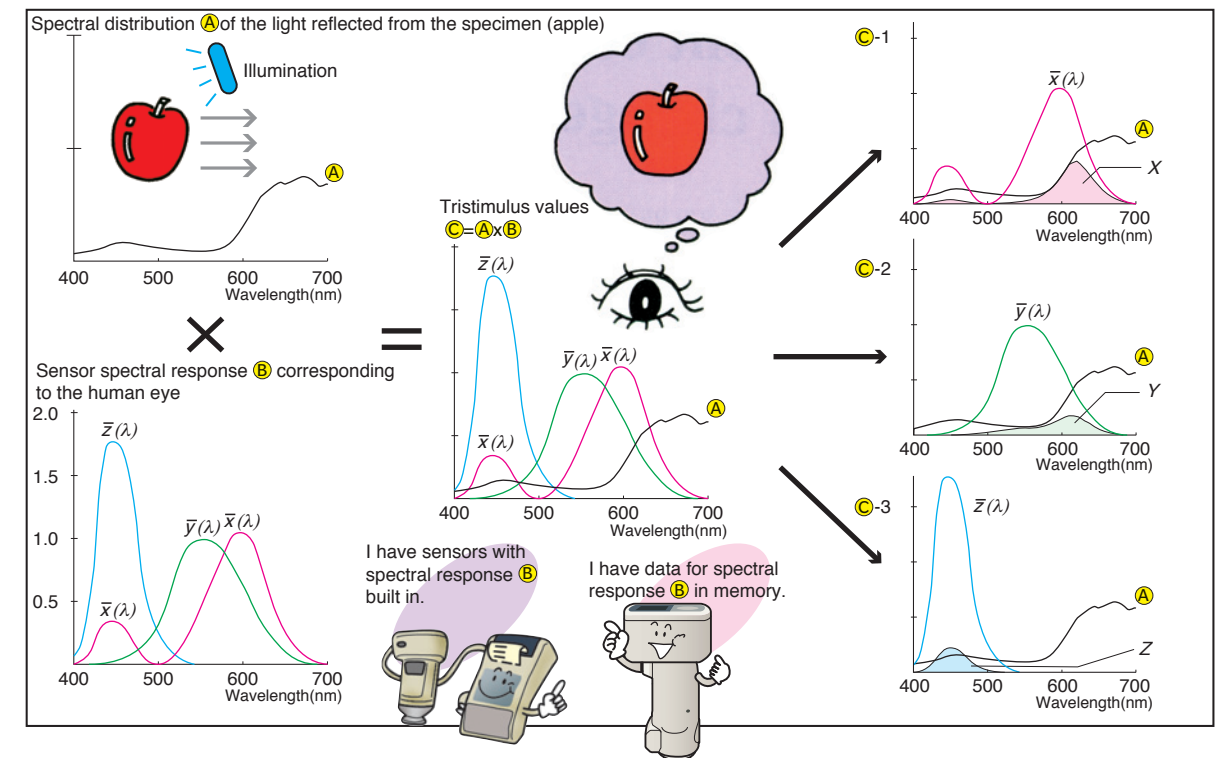

Figure 15: The human eye and instrument measuring methods



incident on sensors with spectral response **B**, whose filters divide the light into wavelength regions corresponding to the three primary colors and the sensors output the tristimulus values (X , Y , and Z) **C**. Thus, $\mathbf{C} = \mathbf{A} \times \mathbf{B}$. The results in the three wavelength regions of **C** are also shown: **C**-1: $\bar{x}(\lambda)$, **C**-2: $\bar{y}(\lambda)$, and **C**-3: $\bar{z}(\lambda)$. The tristimulus values are equal to the integrations of the shaded area in the three graphs.

Figure 16: Determination of the tristimulus values in color measurements



Spectral reflectance graph

In addition to displaying numerical color data, a spectrophotometer can also display a graph of the color's spectral reflectance. Colors are created by mixing various wavelengths of light in appropriate proportions. A color meter using the tristimulus method only indicates the position of the target color in the chromaticity diagram of various color spaces. A spectrophotometer separates the light reflected from an object with a diffraction grating, measures spectral reflectance at each wavelength or in each wavelength range by using multiple sensors, and then displays the data on a graph.

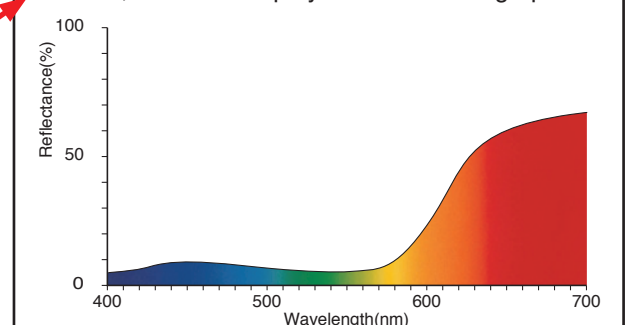

What about the components of light (and color)? Let's take a look.

An object absorbs part of the light from the light source and reflects the remaining light. This reflected light enters the human eye, and the resulting stimulation of the retina is recognized as the object's "color" by the brain. Each object absorbs and reflects light from different portions of the spectrum and in different amounts; these differences in absorptance and reflectance are what make the colors of different objects different.



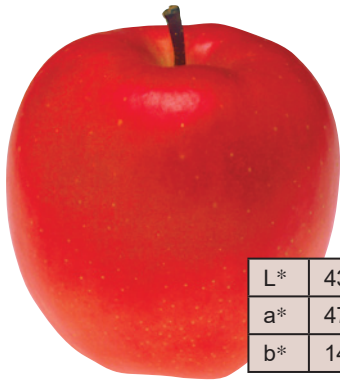

Apple

L*	43.31
a*	47.63
b*	14.12

If we measure an apple, we obtain the spectral graph shown in Figure 17a. If we look at this graph, we see that in the red wavelength region the reflectance (the amount of reflected light) is high, but in other wavelength regions the reflectance (the amount of reflected light) is low. Figure 17b shows that the apple reflects light in the orange and red wavelength regions and absorbs light in the green, blue, indigo, and violet wavelength regions. In this way, by taking a measurement with a spectrophotometer and displaying the results on a spectral graph, we can see the nature of the apple's color. Each of the multiple sensors (36 in the Konica Minolta Spectrophotometer CM-700d) of a spectrophotometer measures light in a strictly defined wavelength region of the visible-light wavelength range. Because of this, the spectrophotometer can measure differences in the elements of color which are not noticeable to the human eye.

Figure 17a:
Spectral reflectance graph for an apple

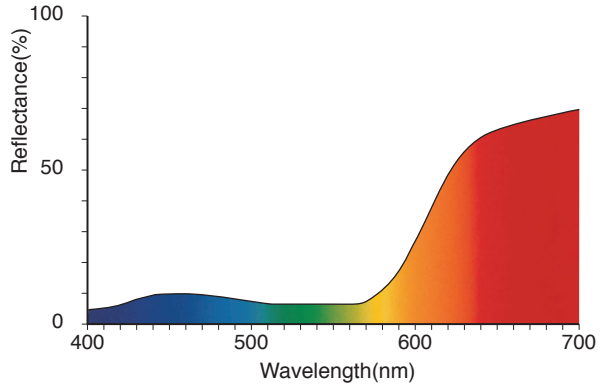
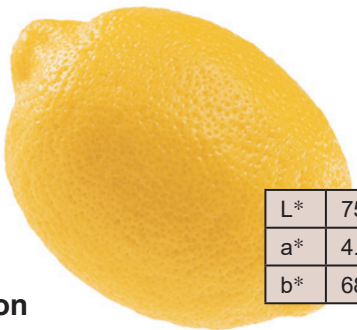
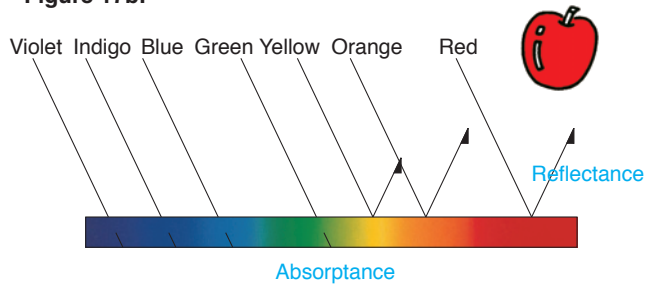

Figure 17b:



Lemon

L*	75.34
a*	4.11
b*	68.54

If we measure a lemon, we obtain the spectral graph shown in Figure 18a. If we look at this graph, we see that in the red and yellow wavelength regions the reflectance (the amount of reflected light) is high, but in the indigo and violet wavelength regions the reflectance (the amount of reflected light) is low. Figure 18b shows that the lemon reflects light in the green, yellow, and red wavelength regions and absorbs light in the indigo and violet wavelength regions. This is the nature of the lemon's color.

Figure 18a:
Spectral reflectance graph for a lemon

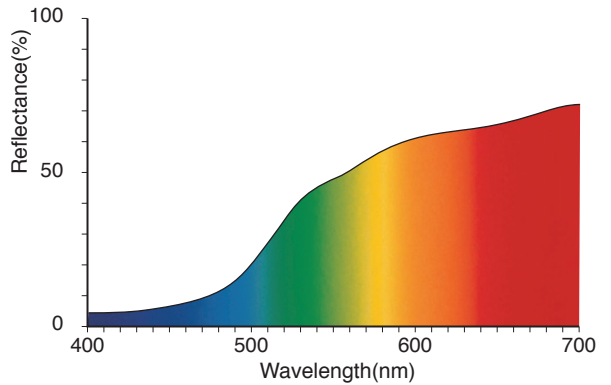
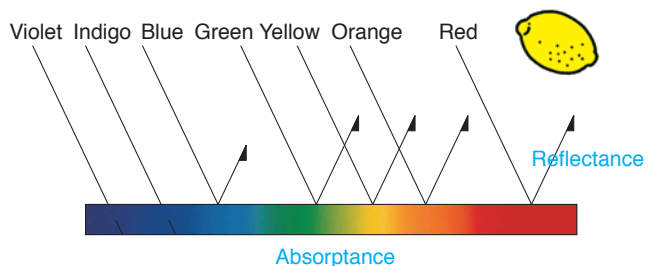

Figure 18b:



Let's measure various colors with a color meter.

With a color meter, we can obtain numerical color data in various color spaces. If we use a spectrophotometer for measurements, not only can we obtain the same types of numerical data, but we can also see the spectral reflectance graph for that color. Further, with its high-precision sensors and the inclusion of data for a variety of illumination conditions, a spectrophotometer can provide numerical color data using various light sources.

A: Tile

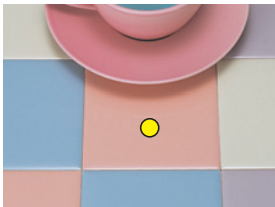

● indicates the measurement point.

L*	74.72
a*	15.34
b*	10.21

A pink tile was measured. By looking at the spectral reflectance graph, we can see that the tile reflects light at all wavelengths, and that the spectral reflectance in the wavelength regions above 600 nm (the orange and red regions) is a bit higher than that of other wavelength regions.

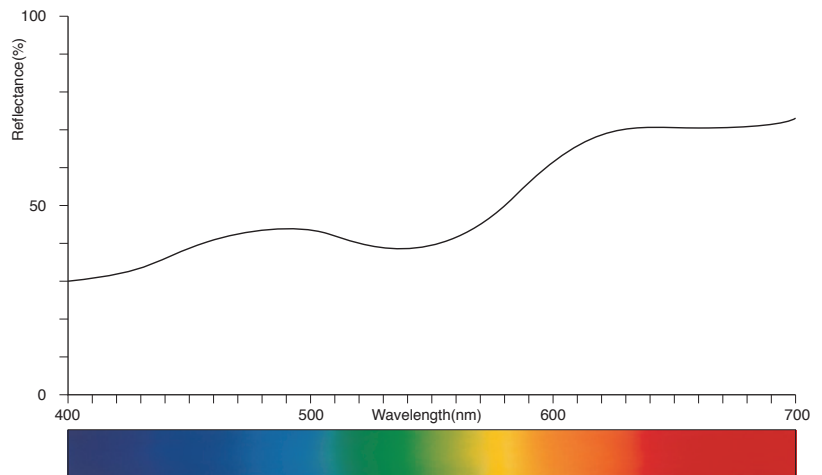

B: Textiles



● indicates the measurement point.

L*	64.51
a*	-36.87
b*	54.69

The green area of the cloth was measured. The spectral reflectance over the entire wavelength range is low, showing a peak of around 520 nm. The spectral reflectance is low at a wavelength of 450 nm or lower and at 600 nm or higher, indicating that blue and red light was absorbed.

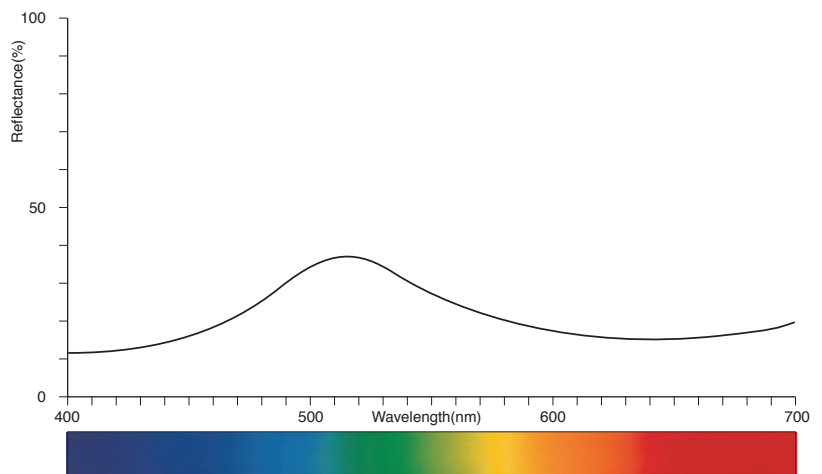

C: Plastic

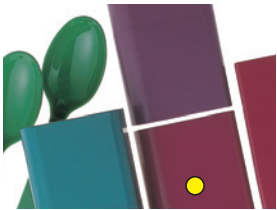

● indicates the measurement point.

L*	34.27
a*	44.53
b*	-21.92

A reddish purple plastic part was measured. The regions around 400 nm and 700 nm have high spectral reflectance, and the wavelength region from 500 nm to 600 nm has low spectral reflectance and we can see that the light is absorbed.

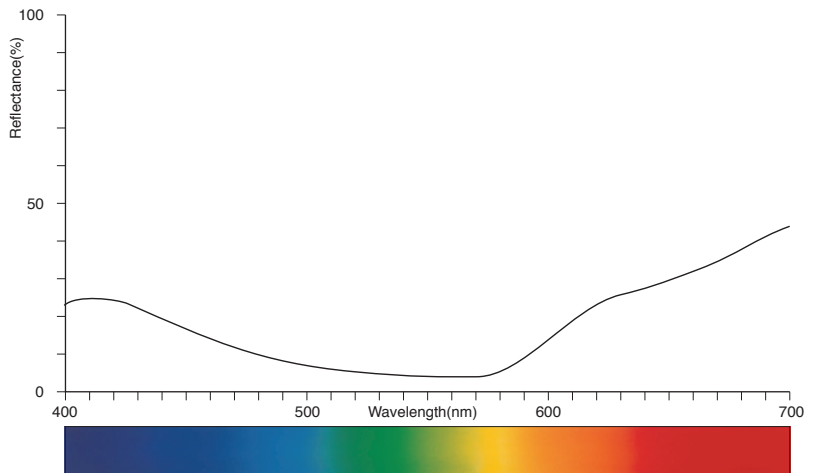

D: Rubber



● indicates the measurement point.

L*	37.47
a*	7.07
b*	-47.77

This is a vivid blue. The spectral reflectance in the wavelength region from 400 nm to 500 nm (the indigo and blue regions) is high, and the spectral reflectance for wavelengths longer than 550 nm is low, with almost all light in this region being absorbed.

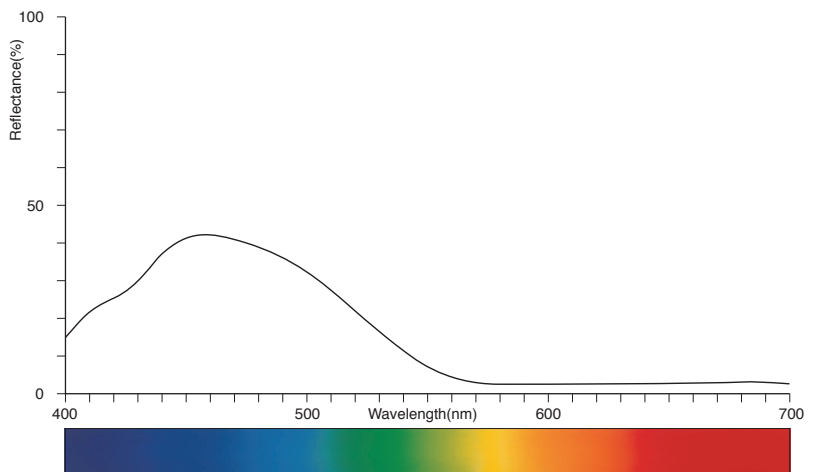

Even though it's actually the same color, it looks different. Why?

Now we understand that color meters can express colors numerically, and spectrophotometers can provide a spectral reflectance graph for the colors. Such numerical data and graphs are effective for color communication, however, there are other color-related problems in color management, and color meters are also useful to solve these problems.

For example, you may have experienced that the same color looks different under different light sources.

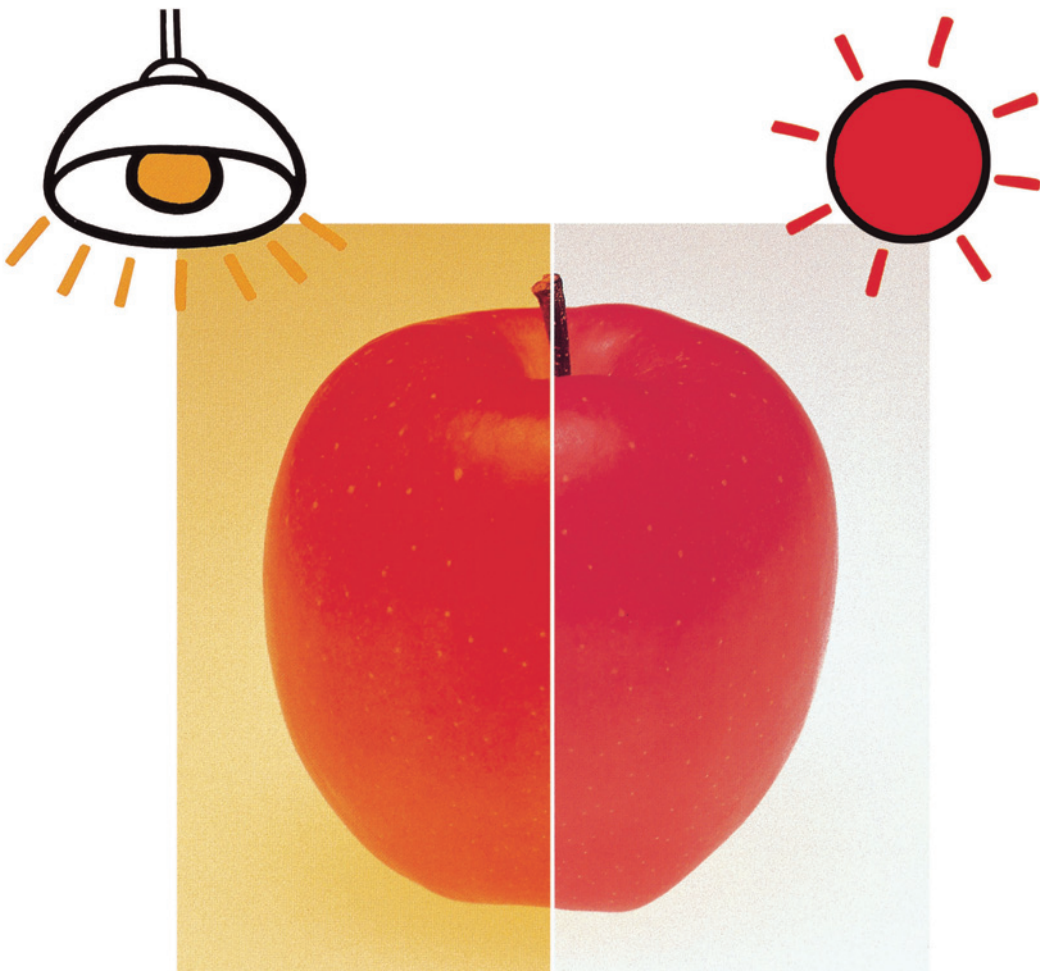

A variety of conditions affect how a color looks.

Light-source differences

An apple which looks so delicious under sunlight in front of the green grocer somehow doesn't look so good under the fluorescent lights at home. Probably many people have had such an experience. Sunlight, fluorescent light, tungsten light, etc.; each type of illumination will make the same apple look different.

Subject condition and environmental differences

Surface condition differences

For example, when sandpaper is applied to the surface of a smooth plastic plate, the color looks duller. Even objects with the same color look different due to the difference in the surface condition.

Observing direction or illumination position differences

In general, viewing an object from just a slightly different angle can make the object appear brighter or darker. This is due to the directional characteristics of the object, which are especially obvious with translucent or metallic colors. The angle from which the object is viewed, and also the angle from which it is illuminated, must be constant for accurate color communication.

Optical illusion; and individual differences

Size differences

After looking at small sample pieces and selecting a wallpaper which looks good, people sometimes find that it looks too bright when it's actually hung on the wall. Colors covering a large area tend to appear brighter and more vivid than colors covering a smaller area. This is referred to as area effect. Selecting objects which will have a large area based on color samples having a small area may result in mistakes.

Background differences

If the apple is placed in front of a bright background, it will appear duller than when it is placed in front of a dark background. This is referred to as contrast effect, and is undesirable for accurately judging color.

Observer differences

The sensitivity of each individual's eyes is slightly different; even for people considered to have "normal" color vision, there may be some bias toward red or blue. Also, a person's eyesight generally changes with age. Because of these factors, colors will appear differently to different observers.

It's important to keep conditions constant when viewing colors.



Colors look different according to the light source.

Different light sources will make colors appear different. Although color meters (both tristimulus type and spectrophotometric type) have built-in illumination, it is not enough for accurate color measurement. Consequently, the CIE and JIS have defined the spectral characteristics of several different types of typical illuminants. Figure 19 shows the spectral power distributions of some of these illuminants. A light source is usually built into the color-measuring instrument. This light source may or may not match any of the CIE illuminants; instead, the instrument determines the data for measurements under the selected illuminant through calculations based on the data actually measured under the instrument's light source and the illuminant's spectral distribution data stored in the instrument's memory.

Figure 19a: Standard Illuminants

- ① Standard Illuminant D65: Average daylight (including ultraviolet wavelength region) with a correlated color temperature of 6504 K; should be used for measuring specimens which will be illuminated by daylight including ultraviolet radiation.
- ② Standard Illuminant C: Average daylight (not including ultraviolet wavelength region) with a correlated color temperature of 6774 K; should be used for measuring specimens which will be illuminated by daylight in the visible wavelength range but not including ultraviolet radiation.
- ③ Standard Illuminant A: Incandescent light with a correlated color temperature of 2856 K; should be used for measuring specimens which will be illuminated by incandescent lamps.

Figure 19b: Fluorescent Illuminants (recommended by CIE for measurements)

- ④ F2: Cool white
- ⑤ F7: Daylight
- ⑥ F11: Three narrow band cool white

Figure 19c: Fluorescent Illuminants (recommended by JIS for measurements)

- ⑦ F6: Cool white
- ⑧ F8: Daylight white
- ⑨ F10: Three narrow band daylight white

Figure 19: Spectral Distribution of CIE Illuminants

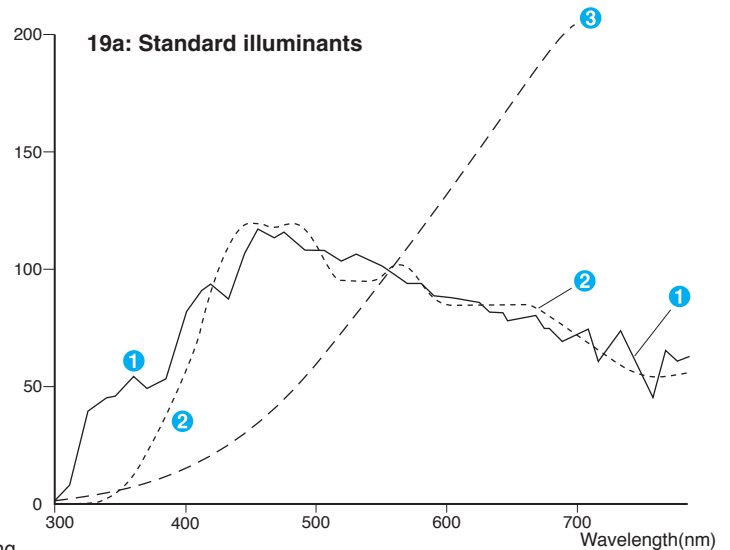

19b: Fluorescent illuminants (recommended by CIE for measurements)

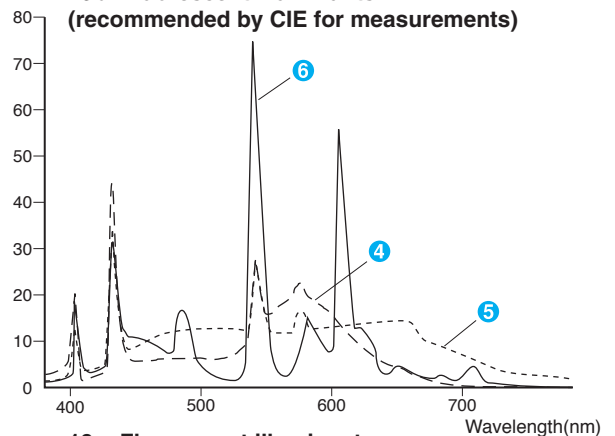

19c: Fluorescent illuminants (recommended by JIS for measurements)

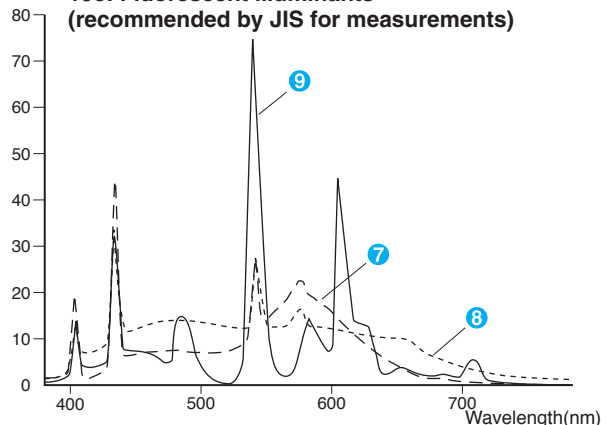

I only have data for ① and ②

I have data for all of them from ① to ⑨

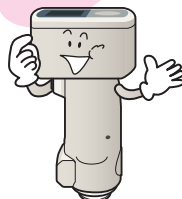
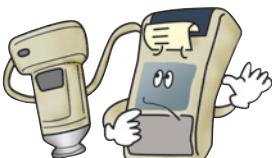

Let's look at examples of what happens if we measure our specimen (apple) using a spectrophotometer under Standard Illuminant D₆₅ (example 1) and Standard Illuminant A (example 2). In example 1, **A** is the graph of the spectral power distribution of Standard Illuminant D₆₅ and **B** is a graph of the spectral reflectance of the apple. **C** is the spectral power distribution of the light reflected from the specimen (apple) and is the product of **A** and **B**. In example 2, **A'** is the spectral power distribution of Standard Illuminant A and **B** is the spectral reflectance of the specimen (apple), which is the same as in example 1. **C'** is the spectral power distribution of the light reflected from the specimen (apple) and is the product of **A'** and **B**. If we compare **C** and **C'**, we notice that the light in the red region is much stronger in **C'**, meaning that the apple would appear much redder under Standard Illuminant A. This shows that the color of a subject changes according to the light under which it is viewed. A spectrophotometer actually measures the spectral reflectance of the specimen; the instrument can then calculate numerical color values in various color spaces using the spectral power distribution data for the selected illuminant and data for the color-matching functions of the Standard Observer.

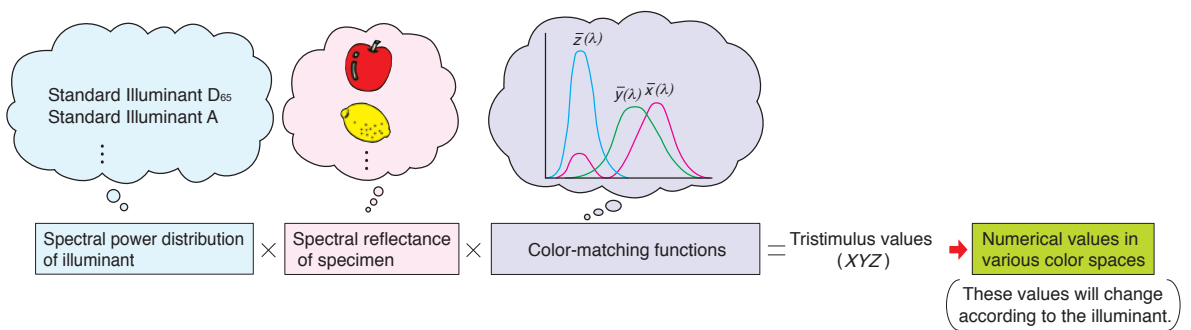

Example 1

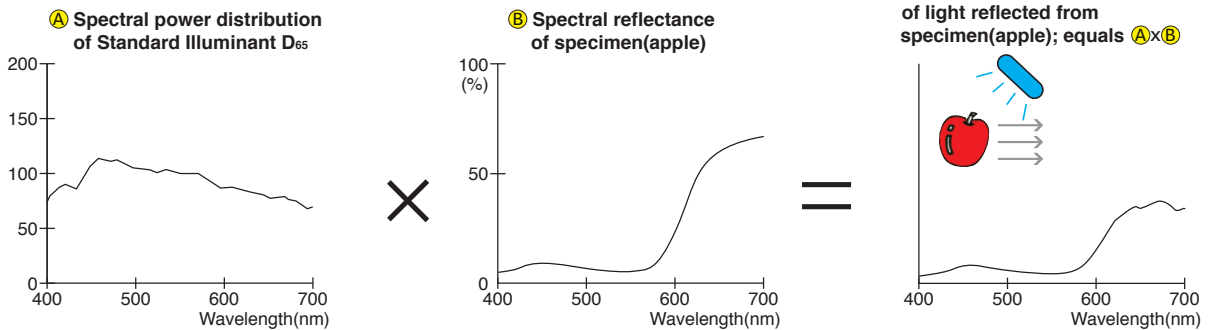

Example 2

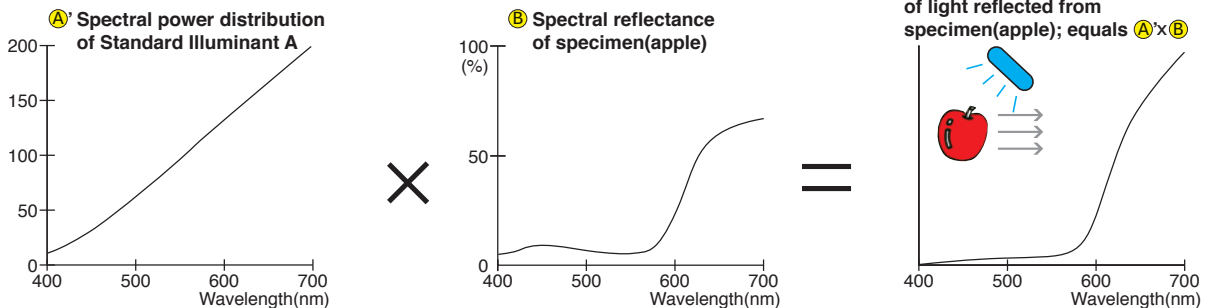

A complex problem: Metamerism

So far, we discussed how the color of an object depends on the light source under which it is viewed. A related problem is, for example, when the colors of two objects appeared to be the same under daylight but appeared to be different under indoor room lighting. Such a phenomenon, in which two colors appear the same under one light source but different under another, is called metamerism. For metameric objects, the spectral reflectance characteristics of the colors of the two objects are different, but the resulting tristimulus values are the same under one light source and different from each other under another. This problem is often due to the use of different pigments or materials. Look at Figure 20. If we look at the spectral reflectance curves for the two specimens, we can immediately see that they are different. However, the $L^*a^*b^*$ values for measurements under Standard Illuminant D₆₅ are the same for both specimens, but the values for measurements under Standard Illuminant A are different from each other. This shows that even though the two specimens have different spectral reflectance characteristics, they would appear to be the same color under daylight (Standard Illuminant D₆₅). So how should metamerism be handled? To evaluate metamerism, it is necessary to measure the specimens under two or more illuminants with very different spectral power distributions, such as Standard illuminant D₆₅ and Standard Illuminant A. Although both tristimulus colorimeters and spectrophotometers use a single light source, they can calculate measurement results based on illuminant data in memory to provide data for measurements under various illuminants. Tristimulus colorimeters can generally take measurements under only Standard Illuminant C and Standard Illuminant D₆₅, both of which represent daylight and which have very similar spectral power distributions; because of this, tristimulus colorimeters cannot be used to measure metamerism. The spectrophotometer, on the other hand, is equipped with the spectral power distributions of a wide range of illuminants and thus can determine metamerism. Moreover, with the spectrophotometer's capability to display spectral reflectance graphs, you can see exactly how the spectral reflectances of the two colors are different.

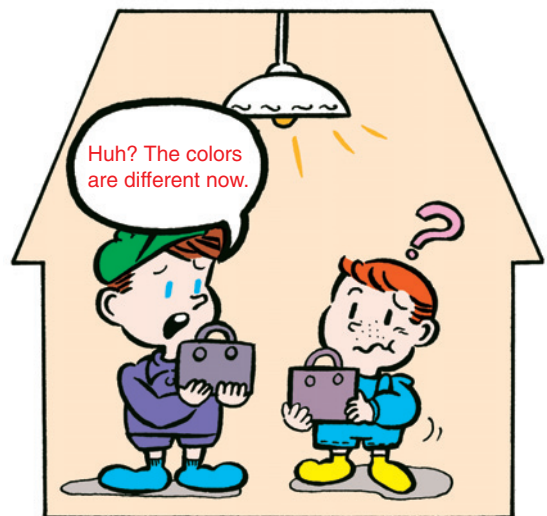
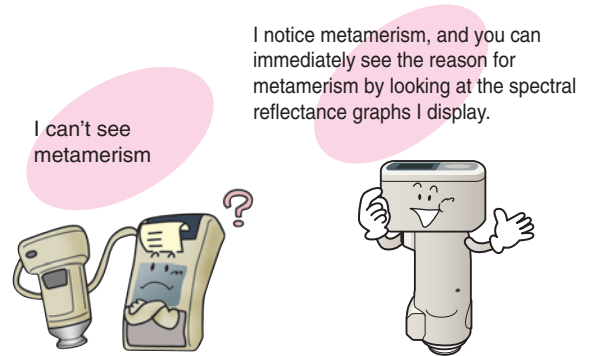
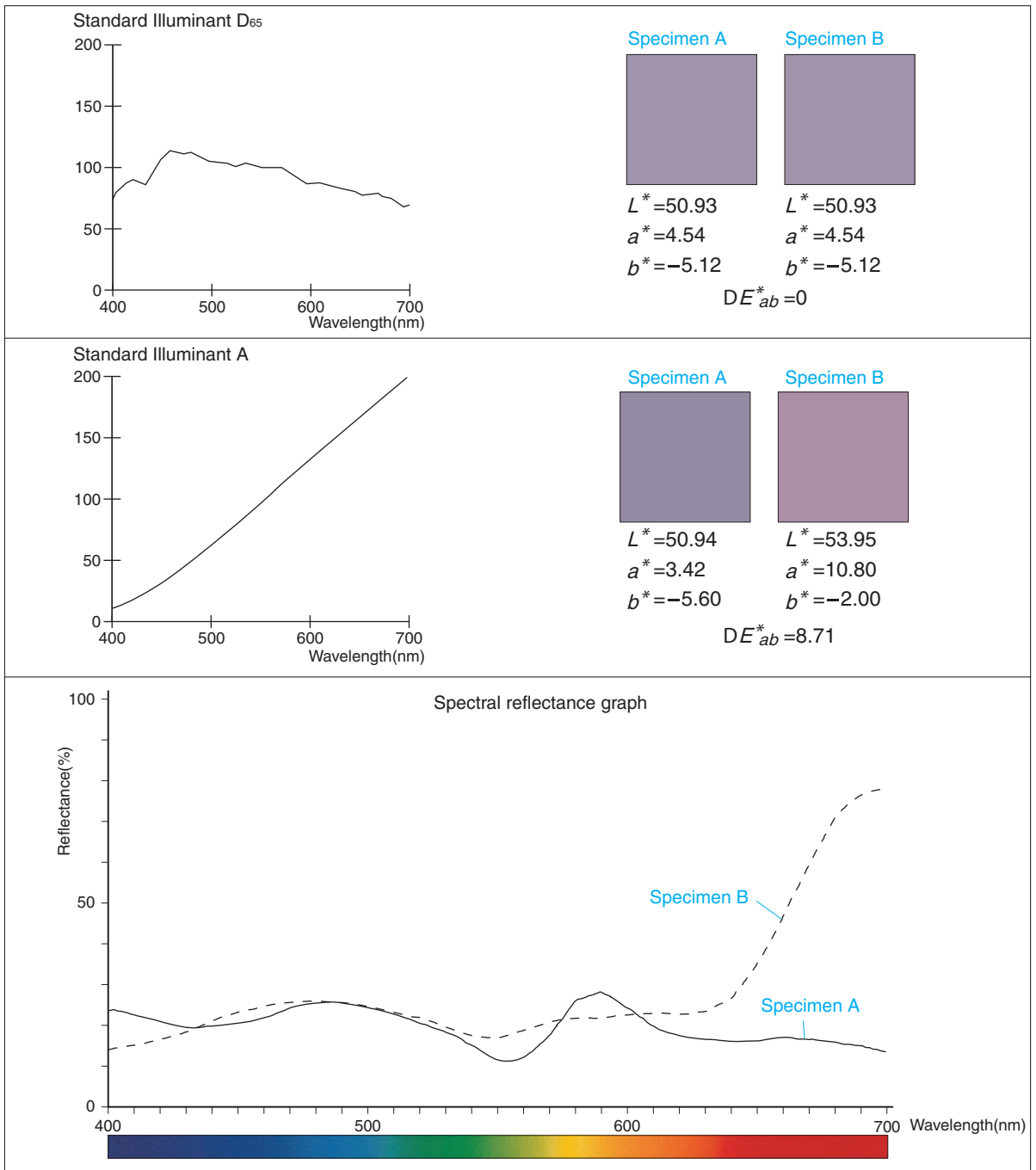

Figure20: Metamerism



•The colors may not be reproduced exactly in this booklet due to the limitations of the printing process.

Colors also look different according to the subject conditions and environment.

Surface condition differences

Even for objects composed of the same materials, variances may be seen in the colors due to differences in the gloss of the surfaces. For example, when sandpaper is applied to a shiny or high gloss blue plastic sample, the color appears as a duller blue. This is because the application of sandpaper changes the surface condition, resulting in diffuse reflection of light.

< Specular reflection and diffuse reflection >

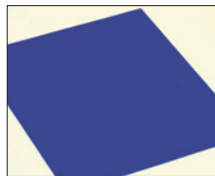

When a ball bounces on a wall and returns, it bounces and returns at the same angle. In the same manner, the light which reflects at the equal but opposite angle from the light source is called the specularly reflected light. This specular component is reflected as if reflected by a mirror. The light that is not specularly reflected, but scattered in many directions, is called diffuse reflectance. The sum of the specular reflectance plus the diffuse reflectance is called the total reflectance.

For objects with shiny surfaces, the specularly reflected light is relatively strong and the diffused light is weaker. On rough surfaces with a low gloss, the specular component is weak and the diffused light is stronger. When a person views a blue plastic object with a shiny surface at the specular angle, the object does not appear to be as blue. This is because the mirror-like reflection of the light source is added to the color of the sample. Usually, a person looks at the color of an object and ignores the specular reflection of the light source. To measure the color of a specimen in the same manner that it is viewed, the specular reflection must be excluded and only the diffuse reflection must be measured. The color of an object can appear different because of differences in the level of specular reflection.

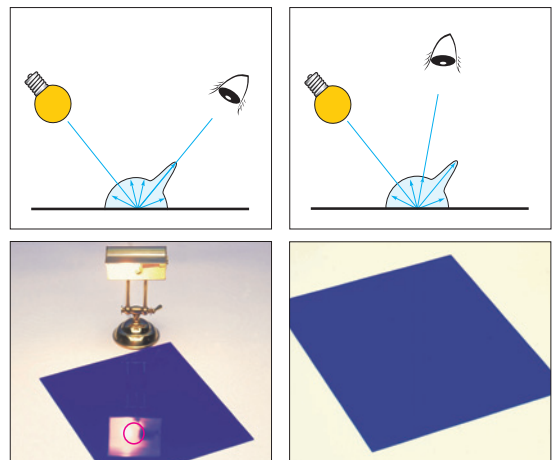
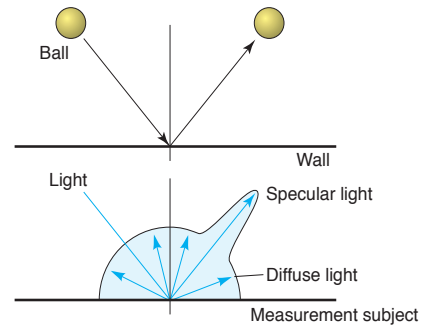
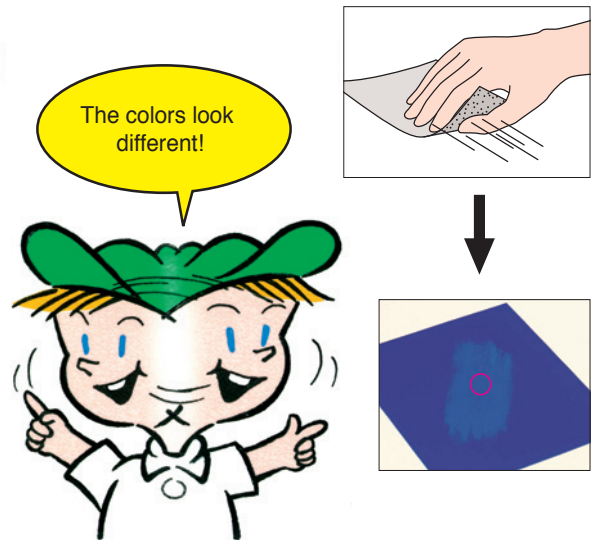

< SCE (Specular Component Excluded) mode and SCI (Specular Component Included) mode >

People recognize the color of an object by viewing the diffuse reflection. If the surface condition of an object is changed, the color of the surface looks different, but the color of the material should be the same. How can we recognize the color of the material?

There are two types of diffuse reflection: Reflection from the inside of an object and reflection from the surface of an object. When the surface condition of an object changes, the diffuse reflection from the inside does not change whereas the diffuse reflection from the surface changes, resulting in the change in the amount of specular reflection and diffuse reflection. Even in such a case, the total amount of the specular and diffuse reflection from the surface is always the same. Therefore, if a glossy blue plastic part is sanded, the specular reflection decreases and the diffuse reflection increases. Consequently, you can measure the color of the material regardless of the surface condition by measuring the total reflection (specular plus diffuse).

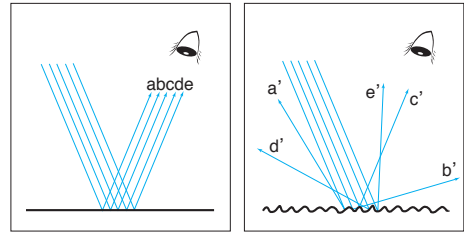

These figures indicate that $a+b+c+d+e=a'+b'+c'+d'+e'$.

The positions of the light trap in Conditions III (SCE) and IV (SCE), as displayed in Figure 21 on the next page, show how the specular reflection is excluded from the color measurement of the specimen. If this trap is replaced with a white plug, as in Conditions V (SCI) and VI (SCI), the specular reflection will be included in the color measurement. The method of color measurement which excludes the specular reflection is called SCE (Specular Component Excluded). If the specular reflection is included in the color measurement, by completing the sphere with a specular plug, it is called SCI (Specular Component Included).

In the SCE mode, the specular reflection is excluded from the measurement and only the diffuse reflection is measured. This produces a color evaluation, which correlates to the way the observer sees the color of an object. The 45°:n and n:45° systems produce a result similar to the SCE mode because the instrument does not receive specular reflection.

When using the SCI mode, the specular reflection is included with the diffuse reflection during the measurement process. This type of color evaluation measures total appearance independent of surface conditions.

The SCE method is effective to verify that the color matches the color standards by visual inspection on the production line.

This method uses a light trap and the specular light is not measured.

The SCI method is effective when color elements are adjusted at the production level such as in CCM.

The measurement is performed without a light trap and specular light is included.

Observing direction or illumination position differences

In general, viewing an object from a slightly different angle can make the object appear brighter or darker. This is due to the directional characteristics of the object, which are especially obvious with translucent or metallic colors. The angle from which the object is viewed, and also the angle from which it is illuminated, must be constant for accurate color communication.

< Types of Optical Systems (geometries) >

A color looks different depending on the viewing conditions, such as the observation angle and illumination angle. When a color meter measures the color of an object, the conditions, including the angle at which a beam of light from a source strikes the object and the angle at which the light is received by a detector, are called the optical geometry, and are defined by CIE and JIS.

Unidirectional Illumination System

This is a method which provides illumination from one direction (angle). With a geometry of $45^\circ:n$ ($45^\circ:0^\circ$), the specimen surface is illuminated from an angle of 45 degrees to the normal line and the light is received in the normal direction (0 degree). With a geometry of $n:45^\circ$ ($0^\circ:45^\circ$), the specimen surface is illuminated from the normal line direction (0 degree) and the light is received at the angle of 45 degrees to the normal line.

For the $45^\circ:n$ illuminating/viewing system, three types of illumination are available: Annular (Ring-shaped) illumination ($45^\circ a:0^\circ$) with light sources positioned in a circle continuously; circumferential illumination ($45^\circ c:0^\circ$) with light sources positioned in a circle at some intervals; and single-directional illumination ($45^\circ x:0^\circ$).

Diffused Illumination Integrating Sphere System

This system uses an integrating sphere for illuminating and viewing a specimen uniformly from all directions. (An integrating sphere is a spherical device with internal surfaces coated with a white material such as barium sulfate so the light is uniformly diffused). An instrument with $d:n$ ($de:8^\circ$), $D:n$ ($di:8^\circ$) optical geometry illuminates the specimen diffusely and detects the light at 8 degrees to the normal line (8 degrees). An instrument with $n:d$ ($8^\circ:de$), $n:D$ ($8^\circ:di$) optical geometry illuminates the specimen at 8 degrees to the normal line (8 degrees) and collects the light reflected in all directions. (Reflected light within ± 5 degrees from the specular angle can be included or excluded using the SCE/SCI function.)

Figure 21 : Illumination/viewing systems

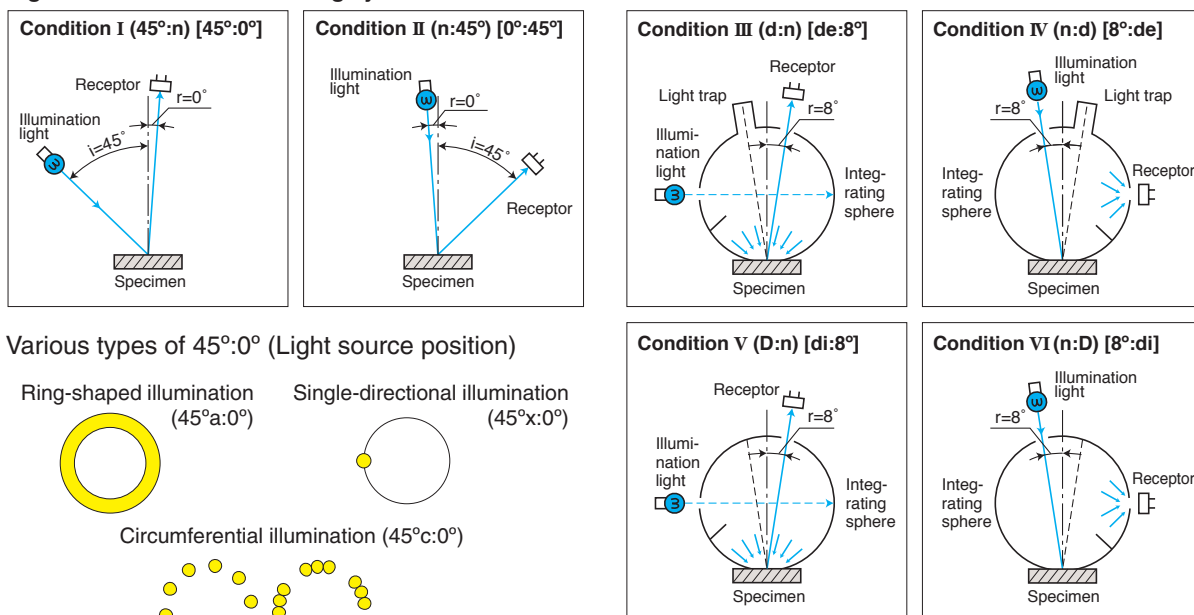

Spectrophotometers solve these problems easily and quickly.

Spectrophotometers offer a wide range of features and superior accuracy so that they can express colors numerically and show spectral reflectance graphs for colors. By using the included data for a variety of illumination conditions, spectrophotometers can solve various problems which could not be solved with tristimulus colorimeters, including color rendering properties (apparent color differences caused by the light source), metamerism, and surface condition differences.

< Major features and functions of spectrophotometers >

Photo shows Konica Minolta Spectrophotometer CM-700d.



Understanding important specifications

With several manufacturers of color-measuring instruments, as well as a single manufacturer offering various types of color-measuring instruments depending on the application and the objects to be measured, how should you choose the best color-measuring instrument for your needs?

What specification items are important depend on how you will use the instrument. For example, if the instrument will often be carried around to take measurements on site or if it will be used to measure several locations on a large object, "Size" and "Weight" in the specification table of the catalog become important, and it might be good choose an instrument that's small and lightweight. But if multiple units will be used at multiple factories, it's important to pay attention to "Inter-instrument agreement" in the specification table and choose a model with small inter-instrument agreement to get better measurement consistency among the factories.

When choosing a color-measuring instrument, how should you read the catalog specification table?

What do items such as "Half bandwidth" or "Repeatability" in the specification table tell you?

This page introduces some of the important items that can be found in the specification table.

For details on the items with balloons, please see the following pages.

	Model	CM-700d	CM-600d
About "Illumination/viewing system"	Illumination/viewing system	di: 8°, de: 8° (diffused illumination, 8-degree viewing angle), SCI (specular component included)/SCE (specular component excluded) selectable with automatic switching (Conforms to CIE No. 15, ISO 7724/1, DIN5033 Teil 7, ASTM E 1164, and JIS Z 8722)	
	Integrating sphere size	ø40 mm	
About "Wavelength range"	Detector	Silicon photodiode array (dual 36-element)	
	Spectral separation device	Diffraction grating	
	Wavelength range	400 nm to 700 nm	
	Wavelength pitch	10 nm	
What is "Wavelength pitch" and "Half bandwidth"?	Half bandwidth	Approx. 10 nm	
	Reflectance range	0 to 175%, Display resolution: 0.01%	
	Light source	Pulsed xenon lamp (with UV cut filter)	
What is "Repeatability"?	Measurement time	Approx. 1 second	
	Minimum measurement interval	Approx. 2 seconds (in SCI or SCE mode)	
	Battery performance	*With alkaline dry batteries: Approx. 2,000 measurements * Stand-alone continuous measurement fixed to either SCI or SCE mode at 10-second intervals at 23°C	
What is "Inter-instrument agreement"?	Measurement/illumination area	*MAV: ø8 mm/ ø11 mm SAV: ø3 mm/ ø6 mm * Changeable by replacing target mask and selecting lens position"	MAV: ø8 mm/ ø11 mm only
	Repeatability	"Spectral reflectance: Standard deviation within 0.1%, Chromaticity value: Standard deviation within E*ab 0.04 (When a white calibration plate is measured 30 times at 10-second intervals after white calibration)"	
About "Size" and "Weight"	Inter-instrument agreement	Within E*ab 0.2 (MA V/SCI) * Based on 12 BCRA Series II color tiles compared to values measured with a master body at 23°C	
	No. of averaging measurements	1 to 10 (Auto averaging), 1 to 30 (Manual averaging)	
	Display	2.36-inch TFT color LCD	
	Interface	USB1.1; Bluetooth® standard version 2.1+EDR*	
	Observer	2° or 10° Standard Observer	
	Illuminant	A, C, D50, D65, F2, F6, F7, F8, F10, F11, F12 (Simultaneous evaluation with two light sources possible)	
	Displayed data	Spectral values/graph, colorimetric values, color difference values/graph, PASS/FAIL result, pseudocolor, color assessment	
	Colorimetric data	L*a*b*, L*C*h, Hunter Lab, Yxy, XYZ, Munsell, and color difference in these spaces (except for Munsell)	
	Index	Ml, Wl(ASTM E313-73/E313-96), Yl(ASTM E313-73/ASTM D1925), ISO Brightness, 8° gloss value	
	Color difference formulas	E*ab (CIE 1976), E*94 (CIE 1994), E00 (CIE DE2000), CMC (l: c), Hunter E	
Data memory	Measurement data: 4,000 sets/Target color difference data: 1,000 sets		
Pass/Fail judgment	Tolerances can be set to colorimetric values (excluding Munsell), color difference values, color values (excluding 8° gloss value) respectively		
Power	Special AC Adapter; 4 AA-size alkaline dry batteries or nickel-metal-hydride rechargeable batteries		
Size (W x H x D)	73 x 211.5 x 107 mm		
Weight	Approx. 550 g (without white calibration cap and batteries)		
Operation temperature/humidity range	5 to 40°C, relative humidity 80% or less (at 35°C) with no condensation		
Storage temperature/humidity range	0 to 45°C, relative humidity 80% or less (at 35°C) with no condensation		

Illumination/viewing system

In order to measure color, the object must be illuminated with light and the light reflected from the object must be measured. For that reason, color-measuring instruments incorporate a light source that emits light, and a sensor that converts the reflected light into an electrical signal.

There are various geometries for illuminating the object with light and receiving the reflected light with sensors, and the measured values differ greatly according to the geometry. Examples of differences in geometries include whether to illuminate the object from one direction or from many directions, whether to include or exclude specularly reflected light, etc.

Because the measured values differ greatly depending on the geometry, it is necessary to choose the geometry carefully according to the type and shape of the object to be measured, and the purpose and application for the measurement. For details, please refer to page 42 <Types of Optical Systems (geometries)> and page 41 <SCE (Specular Component Excluded) mode and SCI (Specular Component Included) mode>.

Size and Weight

For a handheld color-measuring instrument, being smaller and lighter is obviously convenient. Not only does it make the instrument easier to carry around, it also greatly reduces the degree of fatigue when performing repetitive measurements.

However, if the display and operating buttons are too small, the instrument will be difficult to use, so it is necessary to balance size with operability. In addition to size, the shape also needs to be considered: How easy it is to hold, how thick the grip area is, where the fingers fall, etc. And the center of gravity is also important, because if the balance is bad, positioning of the instrument will vary, reducing measurement stability, and the degree of fatigue will also be affected.

Even for benchtop color-measuring instruments, size and weight are also important. Benchtop instruments are often installed in the laboratory with other instruments for measuring properties other than color, and when there are many instruments lined up, having a smaller footprint makes installation easier. Also, being lightweight is more advantageous if the instrument has to be moved.

Wavelength range

The wavelength range is the range of wavelengths that the model can measure. Spectrophotometers usually use either of two measurement wavelength ranges: 400 nm to 700 nm or 360 nm to 740 nm (or 780 in some cases). For general color measurements, the difference between these two measurement wavelength ranges does not greatly affect measured color values.

But for color measurement of certain subjects, using the wider measurement range of 360 nm to 740 nm provides more valuable information. This is particularly true for subjects which include fluorescent whitening agents (FWA) which absorb the energy received from ultraviolet light (generally considered as light below 400 nm), and fluoresce to re-emitting the light at wavelengths in the blue region (from 420 nm to 470 nm). FWA are often included in paper to make them look whiter, making it important to take the fluorescence of FWA into account when measuring paper and pulp or printed materials. Most of our instruments with a 360 nm to 740 nm measurement range also have a UV adjustment function, which enables the measured effects of UV to be adjusted to a standard condition (usually, Standard Illuminant D65), or for the effects of UV to be excluded entirely to measure color without the effects of fluorescence.

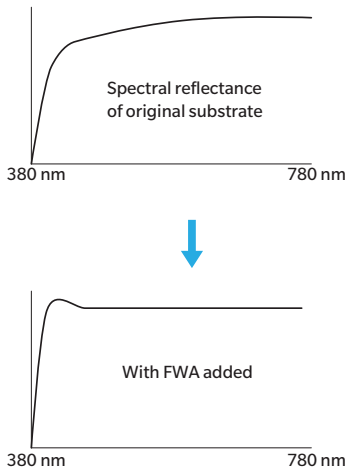

Figure 22 -(1) Fluorescence due to FWA

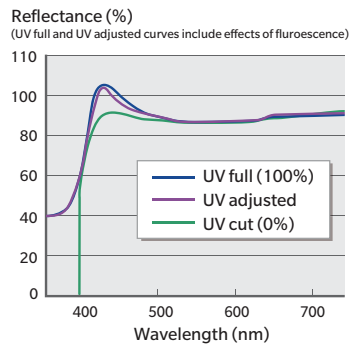
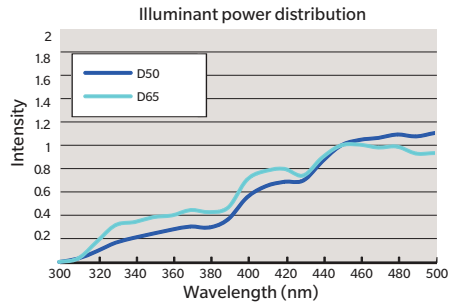

Figure 22 -(2) Spectral curves:
UV light and effects of fluorescence

Wavelength pitch and Half bandwidth

Measurement wavelength pitch is a value indicating at how fine a wavelength interval a spectral type color-measuring instrument can measure. The smaller the pitch is, the more detailed spectrophotometric data can be obtained. However, this does not necessarily mean that the smaller the measurement wavelength pitch is, the better. Since for object color, such as the color of a sample, the spectral characteristics are gentle in most cases, a measurement wavelength pitch of 10 nm is sufficient and a finer pitch is not necessary.

A spectral type color-measuring instrument has sensors that observe light at respective single wavelengths, but the sensitivity of each of these sensors also has a wavelength component (graph horizontal axis direction) spread as shown in Figure 23. The half bandwidth is the width of the sensor's spectral sensitivity curve at a specific wavelength where the sensitivity of the sensor is half of the peak value and it is a value showing how much the sensitivity of the sensor expands in the wavelength direction. The wavelength range between the two half-bandwidth points on the curve with the peak sensitivity wavelength at regarded as the area covered by the sensor.

Figure 23 What is half bandwidth?

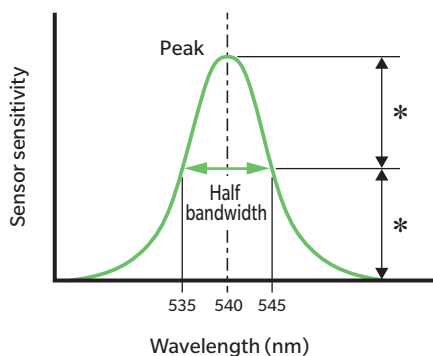

If the half bandwidth of the sensor is large, a wide wavelength range is observed, so the measurement result obtained will be a blunt waveform. In order to accurately measure the original spectroscopic characteristics, it is necessary to reduce the half bandwidth. In other words, the half bandwidth in a color-measuring instrument is "the ability to measure monochromatic light".

Figure 24 is a schematic representation of this. Measurement values at 540 nm and 550 nm from an instrument with a measurement wavelength pitch of 10 nm and a half bandwidth of 10 nm were obtained by observing wavelength ranges of 535 nm to 545 nm and 545 nm to 555 nm, respectively. For measured values at 540 nm and 550 nm from an instrument with a measurement wavelength pitch of 10 nm and half bandwidth of 20 nm wavelength ranges from 530 nm to 550 nm and 540 nm to 560 nm, respectively, were observed. That means measurements also include areas covered by the adjacent sensor, which leads to a measurement results having a blunted waveform. In general, narrowing the half bandwidth improves the measurement accuracy, but it also causes the S / N ratio to deteriorate because the amount of light reaching the sensor decreases. Therefore, it is not sufficient to simply narrow the half bandwidth.

It is said that it is appropriate to have the wavelength pitch and half bandwidth be nearly the same.

Figure 24 Relation between half bandwidth and wavelength pitch

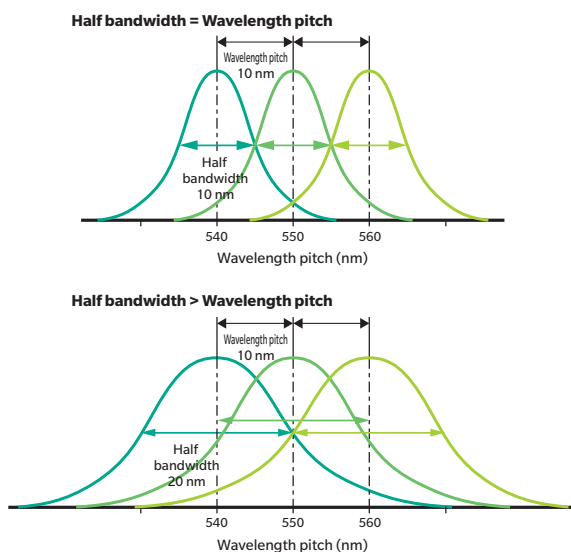

Repeatability

Repeatability is the difference in measured values when taking repeated measurements of the same specimen under the same conditions. The smaller the value, the higher the reliability of the measured value. If this value is large, it is necessary to repeat the measurement many times and obtain the average value in order to obtain a reliable measurement value.

Simple physical quantities like "length" can be measured with a simple mechanism, so measurement errors are small. However, since the measurement of "color" involves a more complicated mechanism, there are many factors that may generate errors.

Therefore, measurement errors inherent in the instrument (after excluding various error factors) are listed in the "specification values" of catalogs. First, after performing white calibration, the white calibration plate is measured repeatedly at specific intervals (for example, 30 times at 10 second intervals) and the standard deviation of the measured values is obtained. In order to eliminate various error factors which may be generated at the time of measurement, the measurement is repeated automatically without touching the instrument at all after the white calibration plate has been set on the instrument. So the remaining errors are measurement errors inherent in the instrument, and superiority and inferiority between models will occur due to the circuit design method, heat generation of the light source, etc. Especially, the influence of heat generated by the light source is large, and instruments using light sources which generate a lot of heat, such as halogen lamps, generally are inferior in repeatability.

On the other hand, the repeatability when measuring actual specimens includes various error factors and becomes a larger value. It is this repeatability that becomes a problem in practical use. In particular, it becomes larger for specimens whose color is not uniform over the entire surface or for three-dimensional specimen, but it is possible to reduce errors and improve repeatability by designing the instrument with such things in mind.

Let's see what kinds of error factors exist and how they are minimized at the time of design.

① Position error

For specimens whose color is not uniform over the entire surface, if the measurement point is slightly different, the measured value will change and repeatability will be poor.

Therefore, by designing the instrument so that the measuring point is easy to check, it makes it possible to position the instrument to measure the same point as much as possible.

For specimens with large unevenness, if averaging of multiple measurements will be performed, the number of repetitions can be reduced by using an instrument with a large measurement aperture.

② Height variation

In a three-dimensional specimen, such as a specimen with a curved surface, if the instrument is not perpendicular to the surface but is tilted, the distance between the measurement aperture and the specimen varies (height variation). If the distance changes, the relative orientation of the illumination/viewing system will be shifted, causing errors in measured values.

By designing the instrument to be easy to hold and to position even when measuring three-dimensional specimens, tilting of the instrument can be minimized.

Also, if the instrument is too heavy, holding it is tiring and positioning the instrument becomes wobbly.

On the other hand, it is also important to reduce the influence of height fluctuation by devising the design of the illumination/viewing system.

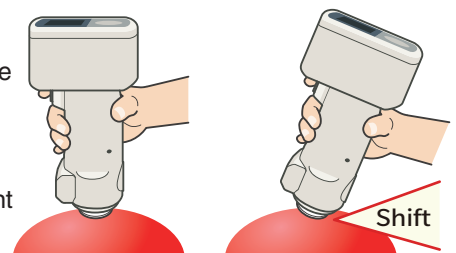

③ Rotation error

Depending on the instrument, the measured value may differ depending on the orientation in which the instrument is applied, as shown in the figure (rotation error). This happens when measuring a specimen with unevenness using an instrument whose distribution of the light source illumination is not uniform. It may also be due to the optical path leading the light reflected by the specimen to the sensor. Such an instrument is difficult to use because it is necessary to strictly control the orientation in which the instrument is applied in order to measure with good stability.

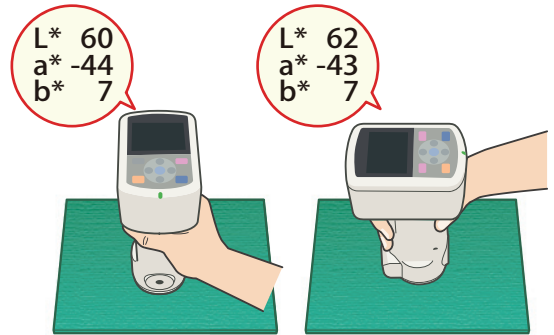

So when comparing the repeatability of two or more models, do not make the comparison with only the "specification value" listed in the catalog. The definition of "specification value" differs depending on the instrument manufacturer, and although in some cases it is about the same as the instrument's capability for actual measurements, there are cases where the "specification value" is much larger than the actual capabilities. It is therefore recommended that you borrow a demonstrator unit, etc. and try out each model's capabilities with your own hands.

Inter-instrument agreement

Inter-instrument agreement is the slight measurement error that occurs between instruments when measuring the same specimen under the same conditions with multiple units of the same instrument model. It is an error caused by slight variations in dimensions and the performance of the optical system components and electronic parts which are used when mass-producing instruments.

In the "specification value" of the catalog etc., the inherent error of the instrument (excluding the influence of temperature and various other measurement error factors) is listed in the section of repeatability. In the case of Konica Minolta instruments, It is determined in a temperature-controlled room by first performing white calibration and then measuring BCRA tiles using a fixture that keeps the measurement position constant. This is the inter-instrument agreement inherent to the instrument. It may be large or small depending on the manufacturers and models, but it can be reduced by using ingenuity in design methods and manufacturing methods.

① Design ingenuity

First, although it is conceivable to specify the dimensional tolerances of optical parts to be as small as possible, increasing the manufacturing accuracy also increases the manufacturing cost. Instead, we devise the optical design so that dimensional errors of parts do not affect errors such as wavelength deviation. In addition, electrical circuits also include factors that may cause instrumental differences, so we devise circuits to stably power the light source, circuits that convert light received by the sensor into electric signals without distortion, etc.

② Manufacturing ingenuity

Since we manufacture large quantities of the same optical parts to mass-produce instruments, we check all those parts and can choose combinations of parts that cancels out the respective errors between parts. Furthermore, by appropriately adjusting the assembled instrument, we can improve inter-instrument agreement.

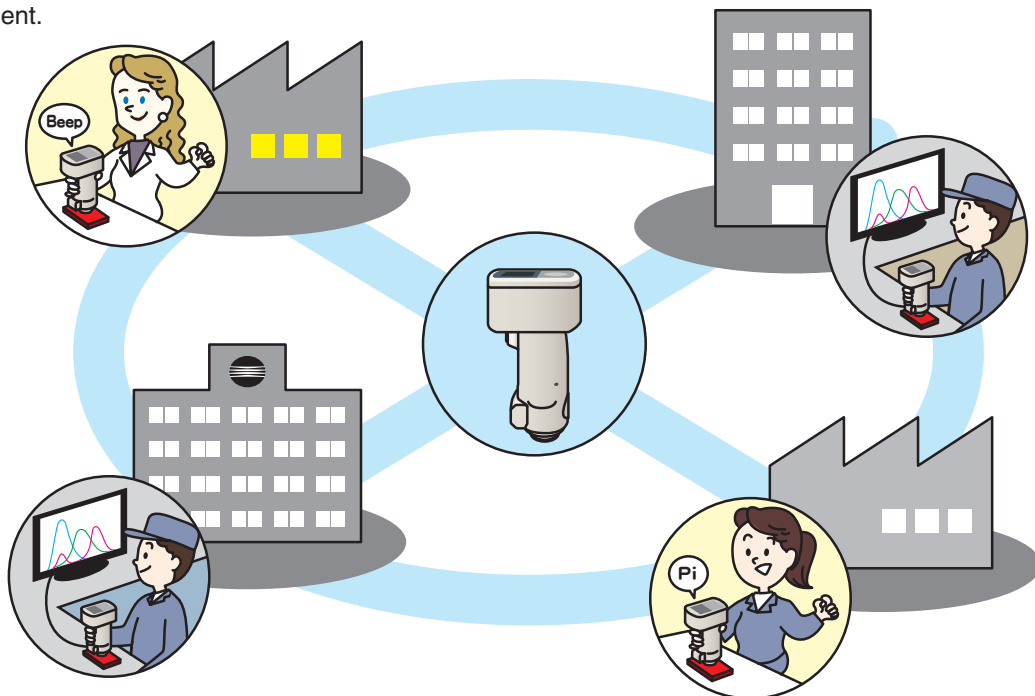

Even if the inter-instrument agreement is improved by such ingenuity, measured values may still deviate due to various error factors in taking the measurement. Please take measurements as consistently as possible so that they are not influenced by local unevenness ,etc. under an environment where temperature control is possible.

Values measured with a model with a small inter-instrument agreement value will be more reliable, so you can use the measured values for communicating color information to remote parties via the internet, etc. In other words, color information can be transmitted by sending measurement values without sending the real thing such as color samples.

On the other hand, when strict color management will be performed for shipment control, etc., the inter-instrument agreement should not be ignored, even if it is small. Specifically, do not use the values measured by another instrument as the target color data when calculating the color difference. If used, error due to inter-instrument agreement will be added to the target color data and the measured value of the sample being compared, and the correct color difference cannot be measured. In addition, the results may be different from visual evaluation. Therefore, in order to perform accurate color management, both the target color and the sample to be compared must be measured with the same instrument.

Measuring Special Colors

< Metallic Colors >

Many coatings, especially automotive applications, use a combination of metallic flake and colorant to achieve a colorful effect. In a metallic coating, light is reflected at different angles due to the orientation of the flakes of metal in the coating, although the flakes will generally be aligned in the same direction. Figure 25 illustrates how the specular reflectance and diffuse reflectance interact with a metallic coating. Because the color reflects from the metallic flake at a different angle than the diffuse reflectance, the appearance to the human eye will also differ. At the angle close to the specular reflection, highlight color (face), which is influenced by the metallic flake, is seen. At the angle, which is not influenced by metallic flake, shade color (flop) is seen. In general, when measuring metallic colors, it is more effective to measure and evaluate them with a spectrophotometer that measures color at multiple angles.

< Fluorescent colors >

When you see a fluorescent color, it looks like it is glowing by itself although it is not actually a light source. When light is applied to a fluorescent material, the rays are absorbed and re-emitted as visible light in other regions of the spectrum, usually at longer wavelengths. Visible light is electromagnetic radiation between approximately 380 nm and 780 nm. For example, when 360 nm radiation is absorbed and emitted at 460 nm, the measurement value at 460 nm may exceed 100%. Since more than the expected amount of light is visible, it appears to the human eye as if the material glows by itself. For measurement of non-fluorescent samples, the dispersive element (such as a diffraction grating) can be placed either between the source and the sample or between the sample and the receiver. However for the measurement of fluorescent samples to agree with the color as it appears to people, the dispersive element must be placed between the sample and the detector so that the sample is illuminated by the entire spectrum of the source. When the fluorescent color is measured by a spectrophotometer, the spectral power distribution of the light source, including the ultraviolet regions, must be controlled.

Figure 25

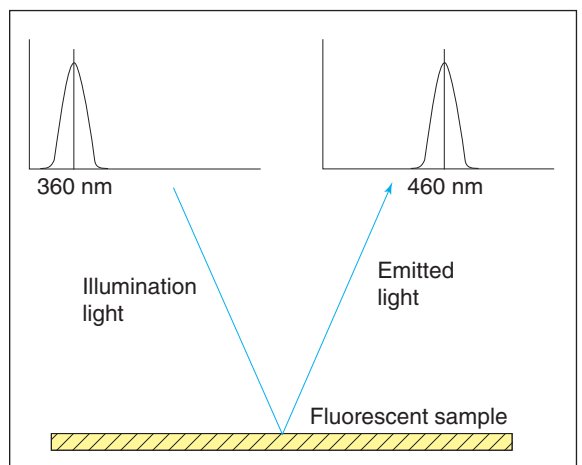
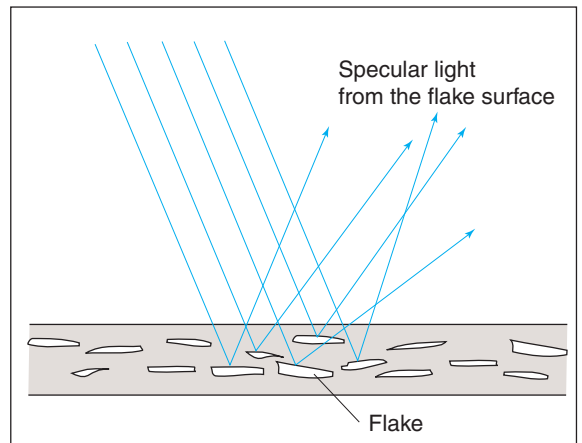
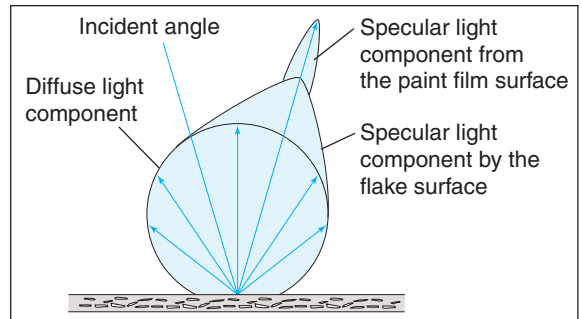

Black Light and Fluorescent Material

Have you ever been in a room where appearances are striking because the white shirts, socks or patterns on the wall seem to be glowing and exceedingly bright while the room itself appears to be dark or illuminated in violet lighting?

A place like this is lit by a source called a black light. The black light is an illumination using wavelengths mostly outside the visible regions of the spectrum. It has been sold for illuminating fluorescent jigsaw puzzles or fluorescent minerals. In fact, this black light emits energy in the ultraviolet region. A fluorescent material that absorbs this energy and re-emits it as light in the visible region has been added to the objects. The materials appear to glow when illuminated by a black light.

An object appears white when it reflects all wavelengths in the visible regions at nearly 100 percent. However, if there is less reflectance at the blue wavelengths, the object appears yellowish. In many cases, a fluorescent material (sometimes referred to as an optical brightener) is added.

This fluorescent material provides an increase in reflectance at the blue wavelengths to make the object seem white. As a result, a white shirt appears to glow when it is illuminated by a black light, and appears white in daylight. When white clothes are washed repeatedly, they become yellowish. This is not because they are stained by a yellow color, but because the fluorescent material is washed out and the original color of the cloth has re-appeared. It is a common practice to have the yellowish clothes returned to white by washing with a detergent that contains a fluorescent material.

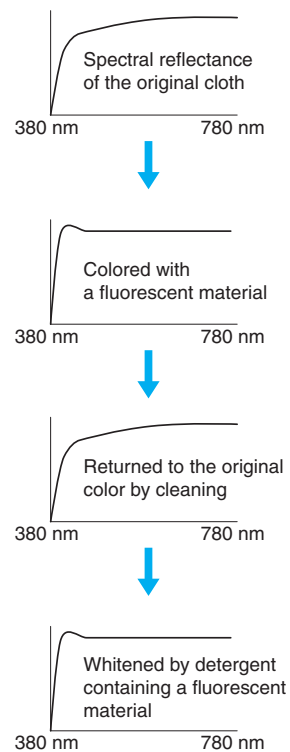

Notes for Measurement (Subjects and Environment)

Powder Measurement Objects

When measuring powder with a spectrophotometer, the measurement value varies depending on the density of the powder and the surface conditions. To avoid errors, special methods are required such as placing a fixed amount of powder into a container of a fixed shape and size and maintaining a fixed surface quality. If the size of the particles is large, use a spectrophotometer which has a large measurement area, so the measurement surface is averaged and a repeatable measurement value can be obtained.

Measurement Objects Containing Patterns

When measuring objects that contain patterns or have textures, the measurement value varies according to the location if a small area. The largest possible measurement area should be used, or else the measurement should be taken several times in different locations, and then the average measurement value should be calculated.

Transmissive Objects

The measurement of transmissive objects such as paper is affected by the light passing through the object. To measure the color of paper, for example, increase the thickness of the object (such as by stacking several sheets of paper) to prevent the light from being transmitted, or place an opaque white surface behind the object. To prevent the effect of the background, use a low-reflectance black surface as a background.

Influence of Temperature Conditions

Sometimes when the temperature of the same object changes, the color will also change. This phenomenon is called thermochromism. To measure color accurately using the spectrophotometer, the measurement must be performed in a room with a fixed temperature after the measurement object has reached the room temperature.

Temperature characteristics when the BCRA color tile changes 10°C from the room temperature (E^*_{ab})
(According to Konica Minolta test conditions.)

E^*_{ab}	
	White
0.01	Pale grey
0.02	Mid grey
0.05	Dif grey
0.05	Deep grey
0.60	Deep pink
1.52	Orange
1.32	Red
0.92	Yellow
0.92	Green
0.91	Dif green
0.46	Cyan
0.17	Deep blue
0.02	Black

New Color Difference Formula (CIE DE2000)

Color meters allow us to accurately communicate colors and color differences using numerical color data. At actual color management locations, however, sometimes the results of visual inspection do not match with the results obtained with color meters. Why? Is there any way to solve this problem? Yes, there is. It is the new color difference formula "CIE DE2000" which will be explained in this section.

Problems with CIE LAB ($L^*a^*b^*$ color space)

CIE LAB ($L^*a^*b^*$ color space) represents colors by using the coordinates in a uniform color space consisting of lightness variable L^* and chromaticity indices a^* and b^* . Although the calculation formula was defined based on the color vision of the human eye, some color differences are evaluated differently between the color difference E^*_{ab} and the human eye. This is because the color discrimination threshold of the human eye greatly differs from the range of color differences E^*_{ab} and a^*b^* defined by CIE LAB.

Color discrimination threshold of the human eye

The human eye cannot differentiate some colors from others even if they are different. The area of such colors on the chromaticity diagram is called the color discrimination threshold of the human eye.

The figure on the right is part of the a^*b^* chromaticity diagram representing the CIE LAB color space. The white ellipses on the diagram represent the color discrimination thresholds of the human eye concerning saturation and hue. In other words, the human eye cannot differentiate the colors within the same ellipse.

A close look at these white ellipses shows the following four characteristics of the color differentiation ability of the human eye on the chromaticity diagram of CIE LAB ($L^*a^*b^*$ color space).

- 1) The sensitivity to color differences is low for the colors with high saturation. Consequently, such colors are difficult to differentiate. (Saturation dependency is high.)

The shape of the ellipses becomes close to a circle for colors with low saturation, and it becomes longer in the direction of saturation and narrower in the direction of hue for colors with high saturation. This means that the human eye cannot differentiate colors with high saturation although their color difference is relatively great.

The human eye cannot differentiate the colors within this ellipse.

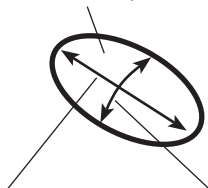

Long in saturation direction
(Colors are difficult to differentiate.)

Narrow in hue direction
(Colors are easier to differentiate.)

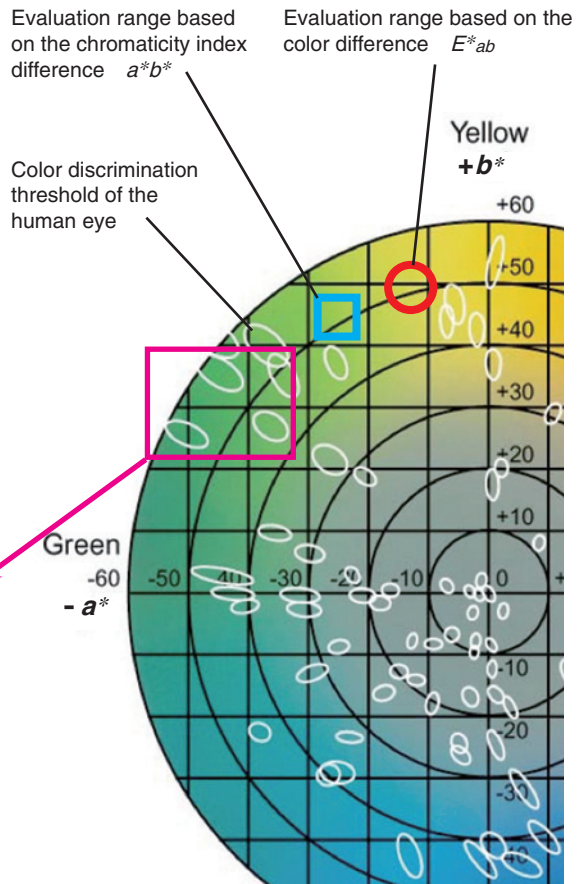

Note: The figures showing white ellipses representing the color discrimination thresholds of the human eye used on pages 56 and 57 are based on Figure 1 excerpted from the paper titled "The Development of the CIE DE2000 Colour-Difference Formula: CIE DE2000" written by M.R. Luo, G. Cui, and B. Rigg, which appeared in COLOR Research and Application, No. 5 (Volume 26), page 341 published in October, 2001, with the cooperation and approval of the journal and authors. Figure 1 on page 341 of the journal is copyrighted by John Wiley & Sons, Inc.

2) The sensitivity to the color differences in the direction of hue varies depending on the hue. Look at white ellipses A and B in the diagram. A is located around the hue angle of 120 degrees (yellowish green), and B is located around the hue angle of 180 degrees (green). Although their saturation is similar, A is wider in the direction of hue, and B is narrower. This means that the sensitivity to the color differences regarding hue is higher in B than in A.

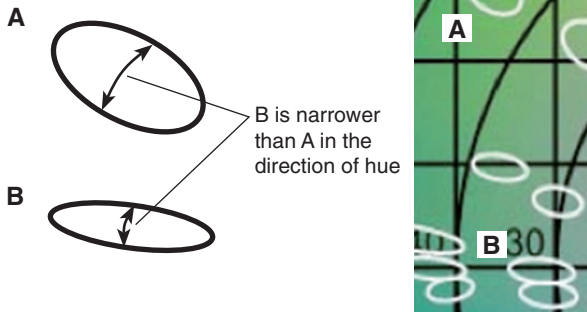

3) The sensitivity to the color difference in the direction of lightness varies depending on the lightness. Unfortunately, the lightness cannot be seen in the figure because it is represented by a normal line perpendicular to the diagram. It is said that the sensitivity becomes highest around the lightness of 50, and decreases for both higher and lower lightness.

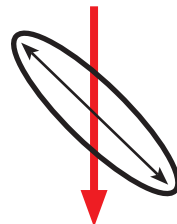

Direction of saturation



The major axis of the white ellipse representing the color discrimination threshold of the human eye is not in the direction of saturation.

4) For blue colors, the direction of the color discrimination threshold changes. The figure shows that the major axes of the white ellipses for blue colors do not match with the direction of saturation spreading from the center. It is this mismatch that causes differences in the color difference evaluation between color meters and the human eye.

The color difference E^*_{ab} generally used for the color difference evaluation with CIE LAB ($L^*a^*b^*$ color space) is represented by a perfect circle for every saturation and hue as shown by \circ in the figure on the right. The chromaticity index difference a^*b^* , another commonly-used evaluation method, is represented with a square as shown by \square in the figure. Both shapes differ considerably from the shape of the color discrimination threshold of the human eye (white ellipse).

The differences in these shapes manifest themselves as the differences between the calculation result by color meters and the evaluation by the human eye.

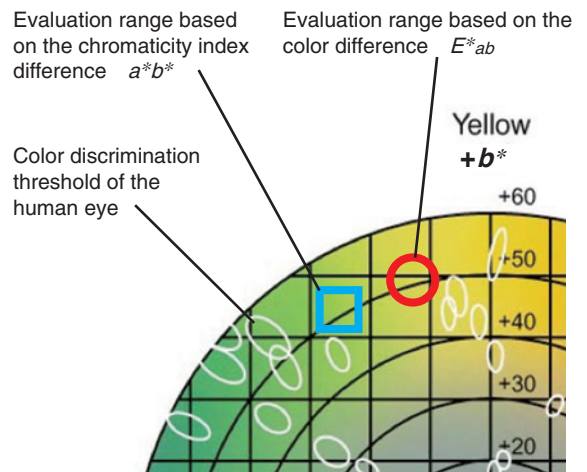

Features of "CIE DE2000" color difference formula

The CIE DE2000 color difference formula was developed to solve the problem of the differences in the evaluation between color meters and the human eye caused by the difference in the shape and size of the color discrimination threshold of the human eye.

The CIE DE2000 color difference formula is not an attempt to build a color space in which the widths of the color discrimination thresholds of the human eye are uniform. Instead, it defines a calculation so that the color difference calculated by color meters becomes close to the color discrimination threshold of the human eye on the solid color space of CIE LAB ($L^*a^*b^*$ color space). Specifically, weight is assigned to the lightness difference L^* , saturation difference C^* , and hue difference H^* by using weighting coefficients S_L , S_C , and S_h respectively. These weighting coefficients S_L , S_C , and S_h include the effects of lightness L^* , saturation C^* , and hue angle h . Consequently, the calculation incorporates the characteristics of the color discrimination threshold of the human eye on the color space of CIE LAB ($L^*a^*b^*$ color space): 1) Saturation dependency, 2) Hue dependency, and 3) Lightness dependency.

* For the specific calculation formula, refer to the next chapter "COLOR TERMS".

With the CIE LAB ($L^*a^*b^*$ color space) color difference formula, the color difference evaluation ranges represented by color difference E^*_{ab} and chromaticity index difference a^*b^* were a perfect circle or a square in the $L^*a^*b^*$ solid color space. With CIE DE2000, color difference E_{00} is represented with an ellipse having the major axis in the direction of saturation, which is similar to the shape of the color discrimination threshold of the human eye. In the region with lower saturation, the weighing coefficients S_L , S_C , and S_h approach 1 respectively, making the ellipse more circular.

In the region with higher saturation, the weighing coefficient S_C becomes greater compared with other coefficients S_L and S_h , so that the ellipse becomes longer in the direction of saturation (lower sensitivity to saturation differences).

With the CIE DE2000 color difference formula, the effect on the hue angle is also considered. As a result, the formula can cope with another characteristic of the color discrimination threshold of the human eye on the color space of CIE LAB ($L^*a^*b^*$ color space): 4) Change in the direction of the color discrimination threshold around the hue angle of 270 degrees (blue) (deviation from the direction of saturation).

The calculation formula also includes constants k_L , k_C , and k_h , called parametric coefficients. Users can specify their values as desired to obtain flexibility for conducting color management according to various objects.

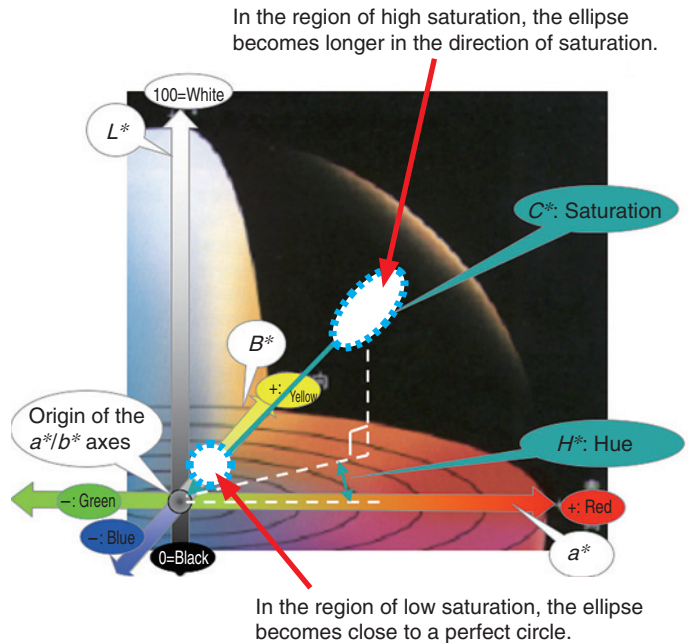

COLOR TERMS

This section includes further details about terms, standards, and color spaces discussed in this booklet. Since the explanation is based on CIE (Commission Internationale de l'Eclairage), some unfamiliar terms and complicated calculations are included. This section is intended as a reference.

2° Standard Observer and 10° Supplementary Standard Observer

The color response of the eye changes according to the angle of view (object size). The CIE originally defined the standard observer in 1931 using a 2° field of view, hence the name 2° Standard Observer. In 1964, the CIE defined an additional standard observer, this time based upon a 10° field of view; this is referred to as the 10° Supplementary Standard Observer. To give an idea of what a 2° field of view is like compared to a 10° field of view, at a viewing distance of 50 cm a 2° field of view would be a $\phi 1.7$ cm circle while a 10° field of view at the same distance would be a $\phi 8.8$ cm circle. The 2° Standard Observer should be used for viewing angles of 1° to 4°; the 10° Supplementary Standard Observer should be used for viewing angles of more than 4°.

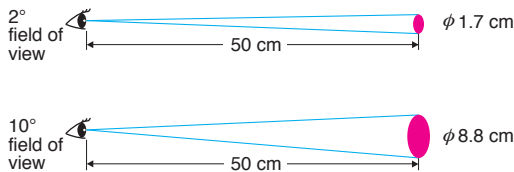

Color-Matching Functions

The color-matching functions are the tristimulus values of the equal-energy spectrum as a function of wavelength. These functions are intended to correspond to the response of the human eye. Separate sets of three color-matching functions are specified for the 2° Standard Observer and 10° Supplementary Standard Observer.

Color-matching functions

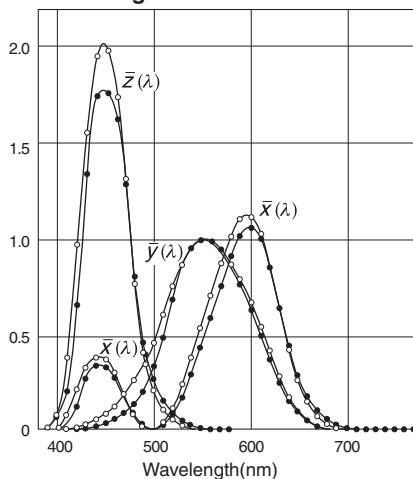

- 2° Standard Observer
- 10° Supplementary Standard Observer

XYZ Tristimulus Values (CIE 1931)

Tristimulus values determined based on the color-matching functions $\bar{x}(\lambda)$, $\bar{y}(\lambda)$, and $\bar{z}(\lambda)$ defined in 1931 by CIE; also referred to as 2° XYZ tristimulus values. They are suitable for a viewing angle of 4° or less and are defined for reflecting objects by the following formulas:

$$X = K \int_{380}^{780} S(\lambda) \bar{x}(\lambda) R(\lambda) d\lambda$$

$$Y = K \int_{380}^{780} S(\lambda) \bar{y}(\lambda) R(\lambda) d\lambda$$

$$Z = K \int_{380}^{780} S(\lambda) \bar{z}(\lambda) R(\lambda) d\lambda$$

$$K = \frac{100}{\int_{380}^{780} S(\lambda) \bar{y}(\lambda) d\lambda}$$

where

$S(\lambda)$: Relative spectral power distribution of the illuminant

$\bar{x}(\lambda)$, $\bar{y}(\lambda)$, $\bar{z}(\lambda)$: Color-matching functions for CIE 2° Standard Observer (1931)

$R(\lambda)$: Spectral reflectance of specimen

X₁₀ Y₁₀ Z₁₀ Tristimulus Values (CIE 1964)

Tristimulus values determined based on the color-matching functions $\bar{x}_{10}(\lambda)$, $\bar{y}_{10}(\lambda)$, and $\bar{z}_{10}(\lambda)$ defined in 1964 by CIE; also referred to as 10° XYZ tristimulus values. They are suitable for a viewing angle of more than 4° and are defined for reflecting objects by the following formulas:

$$X_{10} = K \int_{380}^{780} S(\lambda) \bar{x}_{10}(\lambda) R(\lambda) d\lambda$$

$$Y_{10} = K \int_{380}^{780} S(\lambda) \bar{y}_{10}(\lambda) R(\lambda) d\lambda$$

$$Z_{10} = K \int_{380}^{780} S(\lambda) \bar{z}_{10}(\lambda) R(\lambda) d\lambda$$

$$K = \frac{100}{\int_{380}^{780} S(\lambda) \bar{y}_{10}(\lambda) d\lambda}$$

where

$S(\lambda)$: Relative spectral power distribution of the illuminant

$\bar{x}_{10}(\lambda)$, $\bar{y}_{10}(\lambda)$, $\bar{z}_{10}(\lambda)$: Color-matching functions for CIE 10° Supplementary Standard Observer (1964)

$R(\lambda)$: Spectral reflectance of specimen

xyz Chromaticity Coordinates

The xyz chromaticity coordinates are calculated from the XYZ tristimulus values according to the following formulas:

$$x = \frac{X}{X+Y+Z}$$

$$y = \frac{Y}{X+Y+Z}$$

$$z = \frac{Z}{X+Y+Z} = 1 - x - y$$

If the above formulas are used with the X_{10} Y_{10} Z_{10} tristimulus values, the chromaticity coordinates would be x_{10} y_{10} z_{10} .

xy and x_{10} y_{10} Chromaticity Diagram

Two-dimension diagram on which the xy or x_{10} y_{10} chromaticity coordinates can be plotted.

xy and x_{10} y_{10} chromaticity diagram

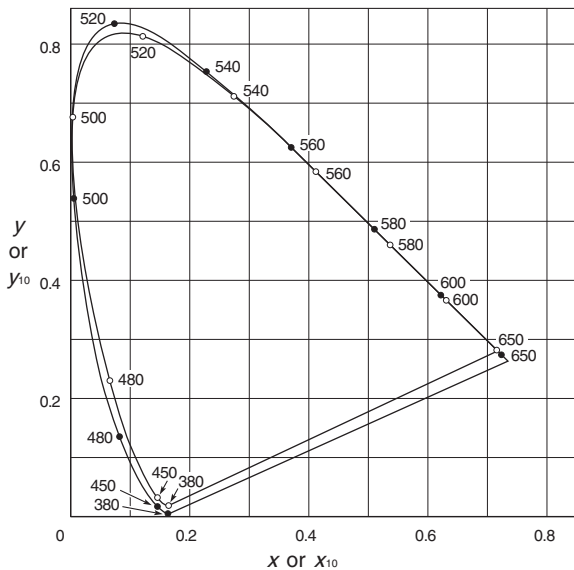

- For 2° Standard Observer (CIE 1931)
- For 10° Supplementary Standard Observer (CIE 1964)

$L^*a^*b^*$ Color Space

The $L^*a^*b^*$ color space (also referred to as CIE LAB) is one of the uniform color spaces defined by the CIE in 1976. The values of L^* , a^* , and b^* are calculated according to the formulas below:

Lightness variable L^* :

$$L^* = 116 \left(\frac{Y}{Y_n} \right)^{1/3} - 16$$

Chromaticity coordinates a^* and b^* :

$$a^* = 500 \left[\left(\frac{X}{X_n} \right)^{1/3} - \left(\frac{Y}{Y_n} \right)^{1/3} \right]$$

$$b^* = 200 \left[\left(\frac{Y}{Y_n} \right)^{1/3} - \left(\frac{Z}{Z_n} \right)^{1/3} \right]$$

where

X, Y, Z : Tristimulus values XYZ (for 2° Standard Observer) or $X_{10} Y_{10} Z_{10}$ (for 10° Supplementary Standard Observer) of the specimen

X_n, Y_n, Z_n : Tristimulus values XYZ (for 2° Standard Observer) or $X_{10} Y_{10} Z_{10}$ (for 10° Supplementary Standard Observer) of a perfect reflecting diffuser.

If X/X_n , Y/Y_n , or Z/Z_n is less than $(6/29)^3$, the above equations are changed as described below:

$$\left(\frac{X}{X_n} \right)^{1/3} \text{ is replaced by } \frac{841}{108} \left(\frac{X}{X_n} \right) + \frac{4}{29}$$

$$\left(\frac{Y}{Y_n} \right)^{1/3} \text{ is replaced by } \frac{841}{108} \left(\frac{Y}{Y_n} \right) + \frac{4}{29}$$

$$\left(\frac{Z}{Z_n} \right)^{1/3} \text{ is replaced by } \frac{841}{108} \left(\frac{Z}{Z_n} \right) + \frac{4}{29}$$

Color difference E^*_{ab} in the $L^*a^*b^*$ color space, which indicates the degree of color difference but not the direction, is defined by the following equation:

$$\Delta E^*_{ab} = \sqrt{(\Delta L^*)^2 + (\Delta a^*)^2 + (\Delta b^*)^2}$$

where

L^*, a^*, b^* : Difference in L^* , a^* , and b^* values between the specimen color and the target color.

Uniform Color Space

A color space in which equal distances on the coordinate diagram correspond to equal perceived color differences.

L*C*h Color Space

The L^*C^*h color space uses the same diagram as the $L^*a^*b^*$ color space, but uses cylindrical coordinates. Lightness L^* is the same as L^* in the $L^*a^*b^*$ color space; Metric Chroma C^* and Metric Hue-Angle h are defined by the following formulas:

$$\text{Metric chroma: } C^* = \sqrt{(a^*)^2 + (b^*)^2}$$

$$\text{Metric Hue-Angle: } h = \tan^{-1} \left(\frac{b^*}{a^*} \right) \text{ [degrees]}$$

where

a^* , b^* : Chromaticity coordinates in the $L^*a^*b^*$ color space

For difference measurements, Metric Hue-Angle difference is not calculated; instead, Metric Hue-Difference H^* is calculated according to the following formula:

$$\begin{aligned} \Delta H^* &= \sqrt{(\Delta E^*_{ab})^2 - (\Delta L^*)^2 - (\Delta C^*)^2} \\ &= \sqrt{(\Delta a^*)^2 + (\Delta b^*)^2 - (\Delta C^*)^2} \end{aligned}$$

The Metric Hue-Difference is positive if the Metric Hue-Angle h of the specimen is greater than that of the target and negative if the Metric Hue-Angle of the specimen is less than that of the target.

CIE DE2000 Color difference formula

As described on page 49 of this booklet, this is the newest color difference formula intended to correct the differences between the measurement result and visual evaluation, which was the weak point in the $L^*a^*b^*$ color space. The calculation is based on the lightness difference L^* , saturation difference C^* , and hue difference H^* , with correction using weighing coefficients (S_L , S_C , and S_H) and constants called parametric coefficients (k_L , k_C , and k_H), as shown below.

$$\Delta E_{00} = \sqrt{\left(\frac{\Delta L'}{k_L \cdot S_L} \right)^2 + \left(\frac{\Delta C'}{k_C \cdot S_C} \right)^2 + \left(\frac{\Delta H'}{k_H \cdot S_H} \right)^2 + R_T \left(\frac{\Delta C'}{k_C \cdot S_C} \right) \left(\frac{\Delta H'}{k_H \cdot S_H} \right)}$$

$$\Delta L' = L' - L'_i = \Delta L^*$$

$$\Delta C' = C' - C'_i = \Delta C^*$$

$$\Delta H' = 2 \sqrt{C' \cdot C'_i} \cdot \sin \left(\frac{h' - h'_i}{2} \right)$$

where

$$L' = L^* \quad a' = a^*(1+G) \quad b' = b^*$$

$$C' = \sqrt{(a')^2 + (b')^2} \quad h' = \tan^{-1} \left(\frac{b'}{a'} \right)$$

$$G = 0.5 \left(\sqrt{1 - \frac{\bar{C}^*_{ab}{}^7}{\bar{C}^*_{ab}{}^7 + 25'}} \right)$$

$$S_L = 1 + \frac{0.015 (\bar{L}' - 50)^2}{\sqrt{20 + (\bar{L}' - 50)^2}}$$

$$S_C = 1 + 0.045 \bar{C}' \quad S_H = 1 + 0.015 \bar{C}' T$$

$$T = 1 - 0.17 \cos(\bar{h}' - 30) + 0.24 \cos(2\bar{h}') + 0.32 \cos(3\bar{h}' + 6) - 0.20 \cos(4\bar{h}' - 63)$$

$$R_T = -\sin(2\Delta \theta) R_C \quad \Delta \theta = 30 \exp \left(- \left(\frac{\bar{h}' - 275}{25} \right)^2 \right)$$

$$R_C = 2 \sqrt{\frac{\bar{C}'^7}{\bar{C}'^7 + 25'}}$$

Munsell Color System

The Munsell color system consists of a series of color charts which are intended to be used for visual comparison with the specimen. Colors are defined in terms of the Munsell Hue (H ; indicates hue), Munsell Value (V ; indicates lightness), and Munsell Chroma (C ; indicates saturation) and written as $H V/C$. For example, for the color with $H=5.0R$, $V=4.0$, and $C=14.0$, the Munsell notation would be: 5.0R 4.0/14.0

The Munsell hue circle



**The Munsell color chip
(The brightness and chroma of 2.5R)**

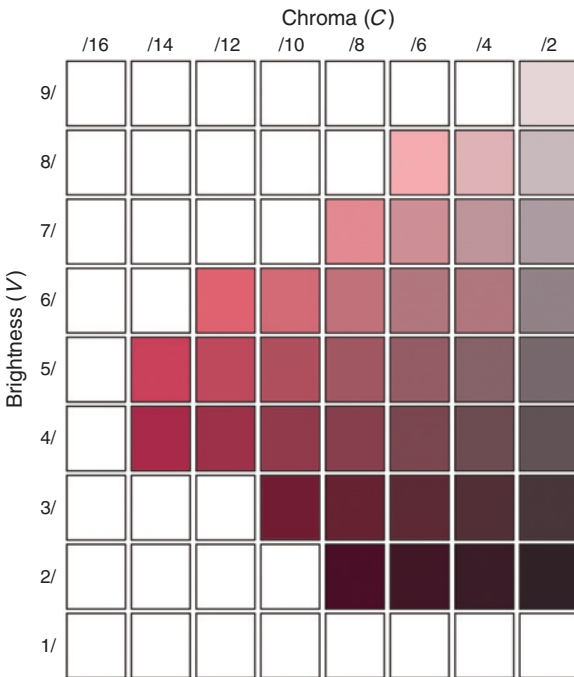

L*u*v* Color Space

The L*u*v* color space (also referred to as CIE LUV) is one of the uniform color spaces defined by the CIE in 1976. The values of L*, u*, and v* are calculated according to the formulas below:

$$L^* = 116 \left(\frac{Y}{Y_0} \right)^{1/3} - 16 \quad \text{when } \frac{Y}{Y_0} > \left(\frac{6}{29} \right)^3$$

$$u^* = 13L^*(u' - u'_0)$$

$$v^* = 13L^*(v' - v'_0)$$

where

Y: Tristimulus value Y (tristimulus value Y₁₀ can also be used.)

u', v': Chromaticity coordinates from the CIE 1976 UCS diagram

Y₀, u'₀, v'₀: Tristimulus value Y (or Y₁₀) and chromaticity coordinates u', v' of the perfect reflecting diffuser.

Color difference E*_{uv} in the L*u*v* color space, which indicates the degree of color difference but not the direction, is defined by the following equation:

$$\Delta E^*_{uv} = \sqrt{(\Delta L^*)^2 + (\Delta u^*)^2 + (\Delta v^*)^2}$$

where

L*, u*, v*: Difference in L*, u*, and v* values between the specimen color and the target color

CIE 1976 UCS Diagram

The CIE 1976 UCS Diagram was defined by the CIE in 1976. It is intended to provide a perceptually more uniform color spacing for colors at approximately the same luminance. The values of u' and v' can be calculated from the tristimulus values XYZ (or X₁₀Y₁₀Z₁₀) or from the chromaticity coordinates xy according to the following formulas:

$$u' = \frac{4X}{X+15Y+3Z} = \frac{4x}{-2x+12y+3}$$

$$v' = \frac{9Y}{X+15Y+3Z} = \frac{9y}{-2x+12y+3}$$

where

X, Y, Z: Tristimulus values (If tristimulus values X₁₀Y₁₀Z₁₀ are used, the results will be u'₁₀ and v'₁₀.)

x, y: Chromaticity coordinates (If chromaticity coordinates x₁₀y₁₀ are used, the results will be u'₁₀ and v'₁₀.)

CIE 1976 UCS Diagram (for 2° Standard Observer)

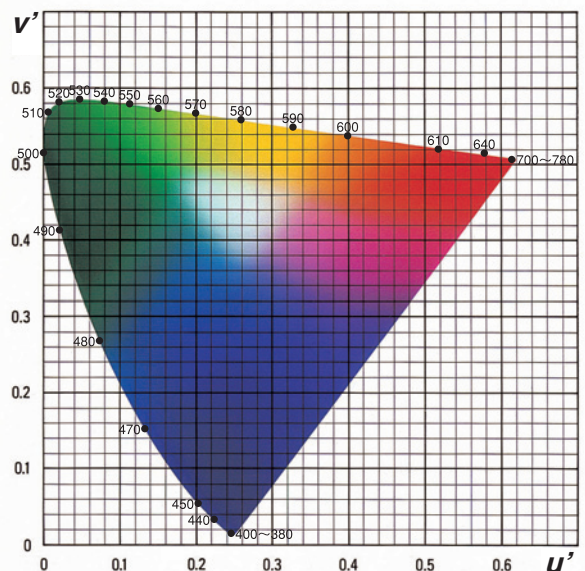

Differences Between Object Color and Source Color

Determining the color of an object was described previously. However, there is a difference when a color is created independently such as by a light bulb. This is called source color. The following is a simple explanation of the differences between object and source color.

Definition Differences

There are three basic factors involved when a human observes the color of an object. They are illumination, the object, and the perception of the observer. However, when a source is observed, there are only two factors: the spectral distribution of the light source and the perception of the observer. The formulas for these concepts are illustrated below.

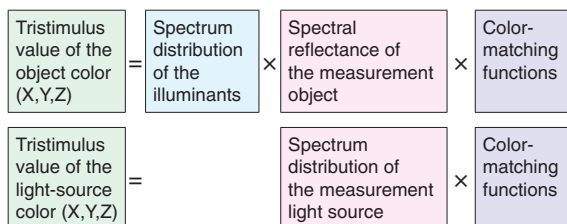

For object color, it is necessary to determine and evaluate the spectral distribution of the illuminants. This is because the color appears differently when the light source varies. The illuminants are not required when the light source color is measured because the color of the light source itself must be determined.

Differences in the Geometrical Conditions of Illumination and Optical Reception

The optical geometry must be considered because the object color may vary under different conditions. Six types of conditions defined by CIE and JIS are described on page 42. These conditions are not used to determine the light source color. However, there are certain angular characteristics in which hue varies depending on the type of the light source and the viewing angle, such as with LCDs. In these cases, the observation angle must be fixed at a set value.

Object Color Definition Formulas

$$X = K \int_{380}^{780} S(\lambda) \bar{x}(\lambda) R(\lambda) d\lambda \quad Y = K \int_{380}^{780} S(\lambda) \bar{y}(\lambda) R(\lambda) d\lambda$$

$$Z = K \int_{380}^{780} S(\lambda) \bar{z}(\lambda) R(\lambda) d\lambda \quad K = \frac{100}{\int_{380}^{780} S(\lambda) \bar{y}(\lambda) d\lambda}$$

Here: $S(\lambda)$: Relative spectral power distribution of the illuminant $\bar{x}(\lambda), \bar{y}(\lambda), \bar{z}(\lambda)$,: Color matching function in the XYZ color space
 $R(\lambda)$: spectral reflectance of the object

Light-Source Color Definition Formulas

$$X = K \int_{380}^{780} S(\lambda) \bar{x}(\lambda) d\lambda \quad Y = K \int_{380}^{780} S(\lambda) \bar{y}(\lambda) d\lambda$$

$$Z = K \int_{380}^{780} S(\lambda) \bar{z}(\lambda) d\lambda$$

Here: $S(\lambda)$: Relative spectral power distribution of the radiant quantity from the light source $\bar{x}(\lambda), \bar{y}(\lambda), \bar{z}(\lambda)$,: Color matching function in the XYZ color space

K : Normalizing color factor
 (The tristimulus value Y is set to conform to the measurement light quantity.)

Use the following equation to determine the absolute value of the measurement light quantity when $S(\lambda)$ is the absolute value of the spectrum radiation density for the XYZ color space.
 $K=683 \text{ lm/w}$

Color Space Representation

There are several common methods to describe light source color numerically. They include the xy coordinates, the CIE 1960 UCS color intensity (u, v), the CIE 1976 UCS color intensity (u^*, v^*), and (color temperature)*

* Refer to the page on the right for information about light source color temperature. The $L^*u^*v^*$ color space (CIE LUV) is also used. However, the standard light must be determined when used in the light source color because the $L^*u^*v^*$ color space is based on the color of a uniformly diffusing surface as an origin point.

Color Temperature

As the temperature of an object increases, the emitted thermal radiation also increases. At the same time, the color changes from red through orange to white. A black body is an ideal object that absorbs all energy and emits it as radiant energy in such a manner so that its temperature is directly related to the color of the radiant energy given off. The absolute temperature of the black body is referred to as the color temperature. These colors would lie in the ideal blackbody locus, as indicated in the xy chromaticity chart shown in Figure 26.

Correlated color temperature is used to apply the general idea of color temperature to those colors that are close to, but not exactly, on the blackbody locus. The correlated color temperature is calculated by determining the isothermure line on which the color of the light source is positioned. Isothermure lines are straight lines for which all colors on the line appear visually equal; the correlated color temperature of any color on the isothermure line is equal to the color temperature at the point where the isothermure line intersects the blackbody locus.

The blackbody locus, the isothermure lines and lines that indicate equal values of uv from the blackbody locus are illustrated in Figure 27. For example, a light source which has a color difference of 0.01 in the green direction (uv) from a black body which has a color temperature of 7000K is indicated as having a correlated color temperature of 7000K+0.01 (uv unit).

Notes

"K" is an abbreviation for Kelvin. Kelvin is the absolute temperature scale.

Figure 26 Blackbody locus on xy chromaticity diagram

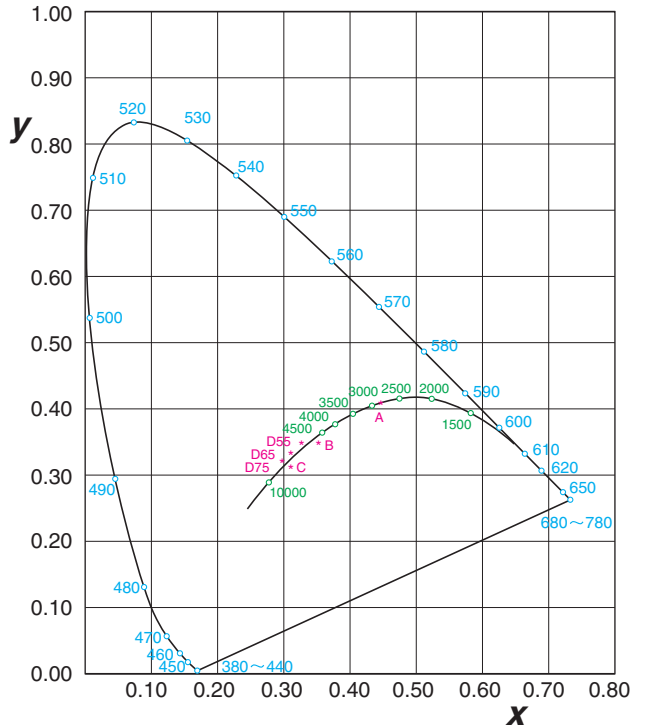
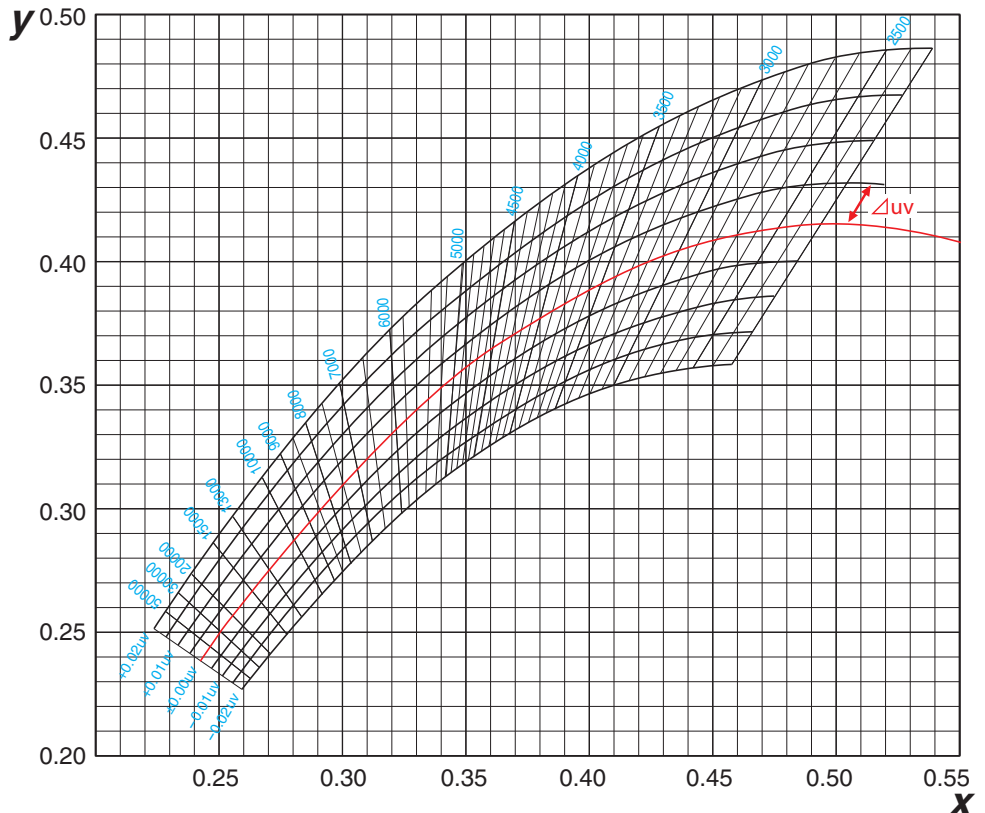

Figure 27 Close up of blackbody locus on xy chromaticity diagram showing correlated color temperature region



Memo

Memo



KONICA MINOLTA